

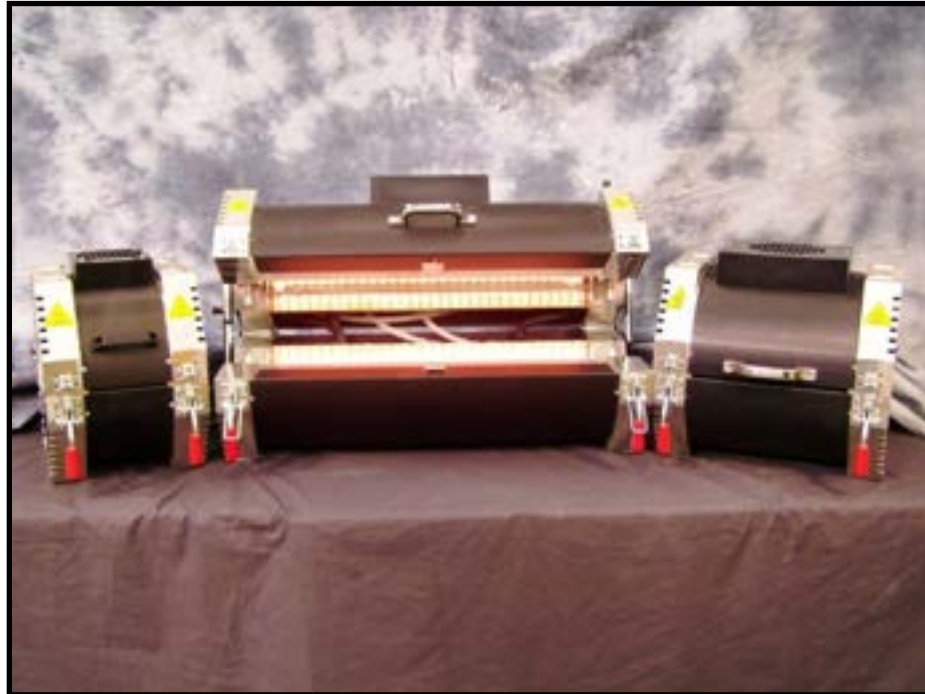

**Model 4069 – User Manual  
Infrared Heaters for Controlled  
Concentrated Curing**



Publication #: A106828-001 Rev. 6C

**November 2015**

**Another quality product from:**



7128 Shady Oak Road, Eden Prairie, MN 55344  
Phone: (952) 949-9009 Fax: (952) 949-9559  
E-mail: [info@researchinc.com](mailto:info@researchinc.com)  
[www.researchinc.com](http://www.researchinc.com)

**Revision History:**

Revision 6.0	November 2013	Changed mounting screw size to 3/8"-16	KJN
Rev.6B	July 2015	Corrected gas spring part number	KJN
Rev. 6C	November 2015	Changed mounting screw size to 3/8-16 pg 15	SL

Copyright © 2012 by Research, Inc. All rights reserved. Under copyright laws, neither the documentation nor the software may be copied, photocopied, reproduced, translated, or reduced to any electronic medium or machine-readable form, in whole or in part, without the prior written consent of Research, Inc., except in the manner described in the documentation.

Research, Inc. reserves the right, without notice, to alter or improve the designs or specifications of the products described herein. No warranty or guarantee of any kind is expressed or implied by information contained herein.

Dear Valued Customer:

Thank you for purchasing a Model 4069 ChambIR® infrared heater. We believe it is the finest heating system of its type and are confident you will think so also.

This instruction manual has been carefully prepared to ensure you will be able to easily install and operate the Model 4069 heater and to fully realize all its inherent capabilities. We invite your comments as well as any issues you may have regarding this manual or the Model 4069.

**Requirement**

**Appropriate Contact**

Additional information regarding application of the Model 4069 heater or other Research Inc. products.

Your local sales representative.

Ordering additional Research Inc. products or Manuals.

Your local sales representative or Research, Inc. Customer Service (952) 949-9009

Technical assistance and training.

Research Inc. Factory Service (952) 949-9009

Once again, let us welcome you to the growing family of Research Inc. customers. We look forward to working with you in the future.

Sincerely,

Randy Baldwin  
President  
Research Inc.

## Contents

<b>Section 1 – INTRODUCTION</b> .....	6
Heater Module .....	6
Water Cooling .....	7
Air Cooling .....	7
Electrical Cable .....	7
Split Quartz Liner .....	7
Power Control System .....	7
<b>Section 2 – FEATURES &amp; BENEFITS</b> .....	8
Rapid Response .....	8
Continuous Operation.....	8
Controllable Energy Output.....	8
<b>Section 3 - SPECIFICATIONS</b> .....	9
Ordering Information.....	11
Ordering Example .....	11
Accessories, Spare, and Replacement Parts.....	12
Replacement Lamps .....	12
Replacement Reflectors.....	12
Replacement end reflectors (polished aluminum) .....	12
Replacement ½ Split quartz liner.....	12
<b>Section 4 – SAFETY</b> .....	13
General .....	13
Latching.....	13
High Temperatures .....	13
Electrical Safety.....	13
<b>Section 5 – INSTALLATION</b> .....	15
Unpack and Check for Damage.....	15
Mounting the Heater.....	15
<b>Section 6 – MAINTENANCE</b> .....	21
<b>Section 7 – SPARE &amp; REPLACEMENT PARTS</b> .....	27
<b>CE Compliance</b> .....	40
<i>Declaration of Incorporation</i> .....	41

## Section 1 – INTRODUCTION

The Model 4069 ChambIR® infrared chamber heater is designed for use in any application that requires a high-intensity, clean, responsive, non-contact heat source. This heater can be used for both continuous processes and test specimens.

Typical applications for the Model 4069 include:

- Curing silicone tubing
- Re-glossing rubber and plastic tubing
- Skin cure automotive hoses and tubing
- Burning lubricant off of extruded wire
- Preheating metal parts prior to rubber or plastic coating
- Curing coatings or adhesives on wire or cable



The Model 4069 includes the following major components:

**Heater Module** – The heater has highly polished aluminum reflectors that direct the infrared energy generated by ceramic end-seal ‘T-3 style’ quartz halogen lamps, which are factory-installed in the heater. Heated lengths of 5, 10, 16, 25, and 38 inches (127,

254, 406, 635, and 965 mm) are offered for the Model 4069. Additional lamps can be ordered separately from the heater.

**Water Cooling** – 90° F(32°C) or less cooling water is required during operation of the Model 4069. Flexible tubing and plumbing fittings are supplied with each heater for easy installation. Required cooling-water flow rates are listed in Specifications. Chilled water below 50° F(10°C) is not required or desired due to possible condensation on reflectors.

**Air Cooling** – A cooling fan is designed into the Model 4069 housing and provides ambient airflow through the heater body. This airflow helps to prevent air-borne process gasses from depositing on the reflector surfaces. It also provides cooling to the quartz halogen lamp end seals.

**Electrical Cable** – The Model 4069 heater is electrically wired from the T3 lamps to intermediate terminal blocks within the heater. Two 12-foot (2.4 m) electrical cables are supplied with each heater.

**Split Quartz Liner** – A split quartz liner is included with the Model 4069 and provides contamination protection for the aluminum reflectors. When installed in the heater, the quartz window protects the aluminum reflector and lamp from contaminants released in the heating process, resulting in maximum efficiency of the heater.

**Power Control System** – The Model 4069 can be ordered with the power control system. An electrical junction box is included and wired directly to the Model 935 ControlIR power control box with 15 feet (4.6 m) of electrical cable. The heater is supplied with two 12-foot (3.7 m) electrical cables and terminated with connectors that plug into the junction box. Please see Figure 5-4, Typical Installation, as well as the Model 935 ControlIR<sup>®</sup> product data sheet for further detail.



## **Section 2 – FEATURES & BENEFITS**

The design and functionality of the Model 4069 supplies a variety of features and related benefits:

**Rapid Response** – The quartz halogen lamps heat up and cool down instantly in response to power control signals. They reach 90 percent of full operating temperature within three seconds of a cold start. The radiant energy dissipates to ten percent five seconds after the power supply is disconnected.

**Continuous Operation** – The formed steel and extruded aluminum construction of the Model 4069, combined with the liquid- and air-cooling, allows the heater to withstand continuous high-temperature operation.

**Controllable Energy Output** – The infrared energy emitted from the heater can be adjusted to match the heating requirements of a variety of applications.

### Section 3 - SPECIFICATIONS

Model Number*	Lamp Lighted Length, Inches (mm)	Lamp Wattage	Lamp Type	Lamp Part Number	Lamp Rated Voltage	Wattage Heater, kW	***Water Flow GPM (LPM)	Pressure Drop Through Heater @ Required Water Flow, psi +/- 5psi	Total Weight, Pounds (kg)
4069-12R-05L-12kW-240V	5 (127)	1000	QIH240-1000RI2	103390-002	240	12.0	1.2 (4.5)	10	65 (30)
4069-12R-05L-12kW-480V	5 (127)	1000	QIH240-1000RI2	103390-002	240	12.0	1.2 (4.5)	10	65 (30)
4069-12R-10L-12kW-240V	10 (254)	1000	QIH240-1000RI4	103390-003	240	12.0	1.2 (4.5)	10	85 (39)
4069-12R-10L-12kW-480V	10 (254)	1000	QIH240-1000RI4	103390-003	240	12.0	1.2 (4.5)	10	85 (39)
4069-12R-10L-24kW-240V	10 (254)	2000	QIH240-2000RI4	103390-004	240	24.0	2.3 (8.6)	22	85 (39)
4069-12R-10L-24kW-480V	10 (254)	2000	QIH240-2000RI4	103390-004	240	24.0	2.3 (8.6)	22	85 (39)
4069-12R-16L-19kW-240V	16 (406)	1600	QIH240-1600RI2	103390-005	240	19.2	1.8 (6.9)	16	95 (43)
4069-12R-16L-19kW-480V	16 (406)	1600	QIH240-1600RI2	103390-005	240	19.2	1.8 (6.9)	16	95 (43)
4069-12R-25L-30kW-480V	25 (635)	2500	QIH480-2500RI2	103390-007	480	30.0	1.4 (5.3)**	31	124 (56)
4069-12R-38L-46kW-480V	38 (965)	3800	QIH480-3800RI2	103390-010	480	45.6	2.1 (8.0)**	63	155 (70)
4069-18R-05L-18kW-240V	5 (127)	1000	QIH240-1000RI2	103390-002	240	18.0	1.7 (6.5)	15	98 (45)
#4069-18R-05L-18kW-480V	5 (127)	1000	QIH240-1000RI2	103390-002	240	18.0	1.7 (6.5)	15	98 (45)
4069-18R-10L-18kW-240V	10 (254)	1000	QIH240-1000RI4	103390-003	240	18.0	1.7 (6.5)	15	112 (51)
#4069-18R-10L-18kW-480V	10 (254)	1000	QIH240-1000RI4	103390-003	240	18.0	1.7 (6.5)	15	112 (51)
#4069-18R-10L-36kW-480V	10 (254)	2000	QIH240-2000RI2	103390-004	240	36.0	3.3 (12.7)	42	112 (51)
4069-18R-16L-29kW-240V	16 (406)	1600	QIH240-1600RI2	103390-005	240	28.8	2.7 (10.2)	29	140 (64)
#4069-18R-16L-29kW-480V	16 (406)	1600	QIH240-1600RI2	103390-005	240	28.8	2.7 (10.2)	29	140 (64)
4069-18R-25L-45kW-480V	25 (635)	2500	QIH480-2500RI2	103390-007	480	45.0	2.1 (7.9)**	61	177 (80)
4069-18R-38L-68kW-480V	38 (965)	3800	QIH480-3800RI2	103390-010	480	68.4	3.1 (11.9)**	37	228 (104)

\* Recommended maximum product diameter of 12-reflector models is two inches. Recommended maximum product diameter of 18-reflector model is four inches.

\*\* Stated flow rates are for each of two flow paths

\*\*\* Maximum inlet-water temperature not to exceed 90°F (32°C)

# Refer to drawing A106827-001 on page 36 of 39 for special wiring instructions of a 240 volt wired heater connected to 480 volts.



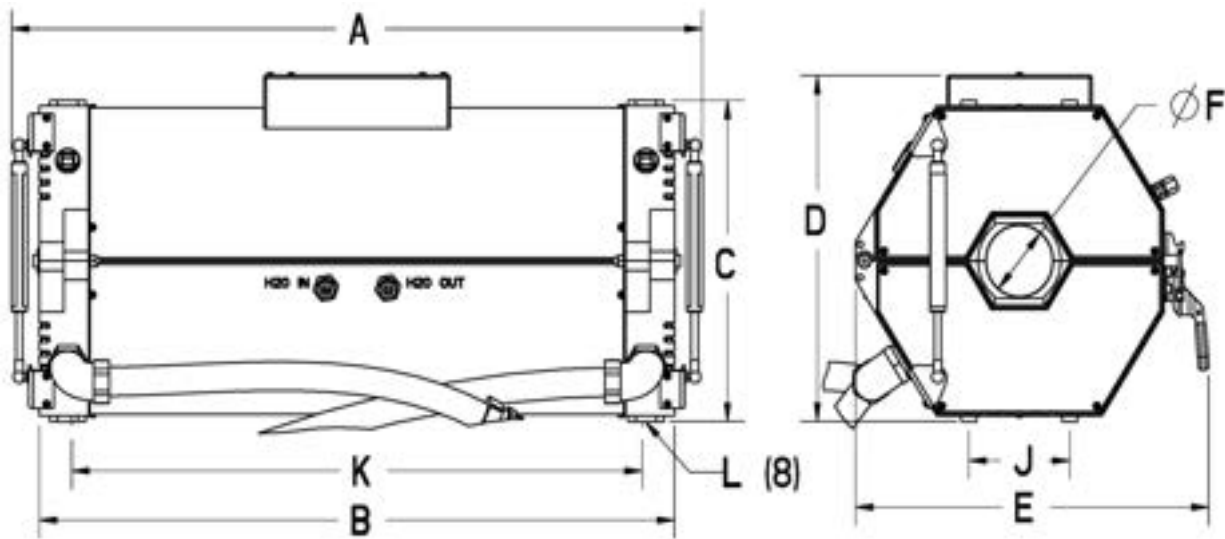

Model Number	Overall Dimensions, Inches (mm)						Mounting Dimension, Inches (mm)		
	A	B	C	D	E	ØF**	J	K	L
4069-12R-05L-XX-XX	13.44 (341)	10.75 (273)	14.5 (368)	15.63 (397)	17.11 (435)	3.22 (82)	4.88 (124)	7.62 (194)	3/8"-16
4069-12R-10L-XX-XX	18.82 (478)	16.13 (410)	14.5 (368)	15.63 (397)	17.11 (435)	3.22 (82)	4.88 (124)	13.00 (330)	
4069-12R-16L-XX-XX	24.44 (621)	21.75 (552)	14.5 (368)	15.63 (397)	17.11 (435)	3.22 (82)	4.88 (124)	18.62 (473)	
4069-12R-25L-XX-XX	33.44 (849)	30.75 (781)	14.5 (368)	15.63 (397)	17.11 (435)	3.22 (82)	4.88 (124)	27.62 (702)	
4069-12R-38L-XX-XX	46.44 (1180)	43.75 (1111)	14.5 (368)	15.63 (397)	17.11 (435)	3.22 (82)	4.88 (124)	40.62 (1032)	
4069-18R-05L-XX-XX	13.27 (464)	10.13 (410)	17.0 (432)	18.55 (471)	20.61 (523)	5.90 (150)	6.06 (154)	7.62 (330)	
4069-18R-10L-XX-XX	18.27 (464)	16.13 (410)	17.0 (432)	18.55 (471)	20.61 (523)	5.90 (150)	6.06 (154)	13.00 (330)	
4069-18R-16L-XX-XX	23.89 (607)	21.75 (552)	17.0 (432)	18.55 (471)	20.61 (523)	5.90 (150)	6.06 (154)	18.62 (473)	
4069-18R-25L-XX-XX	32.89 (835)	30.75 (781)	17.0 (432)	18.55 (471)	20.61 (523)	5.90 (150)	6.06 (154)	27.62 (702)	
4069-18R-38L-XX-XX	45.89 (1166)	43.75 (1111)	17.0 (432)	18.55 (471)	20.61 (523)	5.90 (150)	6.06 (154)	40.62 (1032)	

\* Fully opened angle = 40 degrees

\*\* Recommended maximum product diameter of 12-reflector models is two inches. Recommended maximum product diameter of 18-reflector models is four inches.

**Figure 3-1. Dimensions**

## Ordering Information

Model	Product Description
4069	Parabolic Clamshell Heating System (Includes lamps and split-quartz liner)
Code	Reflector Number
12R	12 Reflectors (Maximum product diameter up to 2 inches)
18R	18 Reflectors (Maximum product diameter up to 4 inches)
Code	Length, Heater Power Rating, Voltage
	<b>12 Reflector Size Availability:</b>
05L-12KW-240V	5-inch length, 12 Kilowatts, 240 Volts
05L-12KW-480V	5-inch length, 12 Kilowatts, 480 Volts
10L-12KW-240V	10-inch length, 12 Kilowatts, 240 Volts
10L-12KW-480V	10-inch length, 12 Kilowatts, 480 Volts
10L-24KW-240V*	10-inch length, 24 Kilowatts, 240 Volts
10L-24KW-480V	10-inch length, 24 Kilowatts, 480 Volts
16L-19KW-240V	16-inch length, 19 Kilowatts, 240 Volts
16L-19KW-480V	16-inch length, 19 Kilowatts, 480 Volts
25L-30KW-480V	25-inch length, 30 Kilowatts, 480 Volts
38L-46KW-480V*	38-inch length, 46 Kilowatts, 480 Volts
	<b>18 Reflector Size Availability:</b>
05L-18KW-240V	5-inch length, 18 Kilowatts, 240 Volts
05L-18KW-480V	5-inch length, 18 Kilowatts, 480 Volts
10L-18KW-240V	10-inch length, 18 Kilowatts, 240 Volts
10L-18KW-480V	10-inch length, 18 Kilowatts, 480 Volts
10L-36KW-480V	10-inch length, 36 Kilowatts, 480 Volts
16L-29KW-240V*	16-inch length, 29 Kilowatts, 240 Volts
16L-29KW-480V	16-inch length, 29 Kilowatts, 480 Volts
25L-45KW-480V*	25-inch length, 45 Kilowatts, 480 Volts
38L-68KW-480V*	38-inch length, 68 Kilowatts, 480 Volts

## Ordering Example

	Model	Reflector Number	Length, Heater Power Rating, Voltage	Optional Power Control System
Typical Model Number	<b>4069</b>	<b>18R</b>	<b>25L-45KW-480V</b>	<b>PC-TI</b>

## Accessories, Spare, and Replacement Parts

Part number	Description
	<b>Replacement Lamps</b>
103390-001	6kW or 9kW, maximum power rated heater (5 inch length, 500W)
103390-002	12kW or 18kW, maximum power rated heater (5 inch length, 1000W)
103390-003	12kW or 18kW, maximum power rated heater (10 inch length, 1000W)
103390-004	24kW or 36kW, maximum power heater (10 inch length, 2000W)
103390-005	19kW or 29kW, maximum power heater (16 inch length, 1600W)
103390-007	30kW or 45kW, maximum power heater (25 inch length, 2500W)
103390-010	46kW or 68kW, maximum power heater (38 inch length, 3800W)
	<b>Replacement Reflectors</b>
106721-015	<b>5 inch length</b>
106721-001	<b>10 inch length</b>
106721-002	<b>16 inch length</b>
106721-003	<b>25 inch length</b>
106721-004	<b>38 inch length</b>
	<b>Replacement end reflectors (polished aluminum)</b>
106778-001	12-reflector size
106778-002	18-reflector size
	<b>Replacement ½ Split quartz liner</b>
106895-009	12 reflector, 5 inch length
106895-001	12 reflector, 10 inch length
106895-002	12 reflector, 16 inch length
106895-003	12 reflector, 25 inch length
106895-004	12 reflector, 38 inch length
106895-010	18-reflector, 5 inch length
106895-005	18-reflector, 10 inch length
106895-006	18-reflector, 16 inch length
106895-007	18-reflector, 25 inch length
106895-008	18-reflector, 38 inch length
M4069	Operational – Users Manual For additional manuals, the latest updated manual or information on other RI products visit <a href="http://www.researchinc.com">www.researchinc.com</a>

## Section 4 – SAFETY

### General

The Model 4069 heater is designed for safe operation. Nevertheless, installation, maintenance, and operation of the heater can be dangerous for a careless operator or maintenance person. For your safety and the safety of others, read the instructions in this instruction manual and follow these safety practices to help prevent accident or injury.

**Only instructed or skilled persons shall be entrusted with the maintenance work on this heater.**

### Latching

A latching shock is installed on the left side of the model 4069 heater. The latch will prevent the heater from closing should the gas strut fail. When closing the heater pull the knob to release the latch while closing.

**INFRARED RADIATION - CAUTION!** Continuous exposure to high-intensity infrared radiation at close proximity could be harmful to eyes or skin. Although infrared lamps emit negligible ultra violet electromagnetic radiation, harmful burns can still result if an operator is in close contact with lamps being operated at high intensity.

Because of the brilliant light emitted by infrared lamps at full intensity, it is recommended that eyes be shielded from the glare if observing the lamps for an extended period of time. Use suitable shaded lenses or dark glasses.

### High Temperatures

Parts of the heater may exceed 500°F (260°C). Contact with the lamps, reflector, or metal parts near the lamps may cause severe burns.

### **WARNING!**

**NEVER** place hands under or in front of the heating elements.

**ALWAYS** allow heating element to cool at least three minutes before touching the lamps or adjacent parts.

### Electrical Safety

There is danger of electrical shock when servicing the heater. **Only instructed or skilled persons shall be entrusted with the maintenance work on this heater.**

**CAUTION!** Observe all applicable local and national electrical codes and ensure that a safe electrical ground system is installed before attempting to operate the heater. Refer to the Section 5 for proper installation procedures.

**WARNING!**

**ALWAYS** disconnect the external power lines prior to servicing the heater.

**ALWAYS** disconnect the power lines **AND** any optional interlock circuits before installing or changing lamps.

**NEVER** operate the heater with end covers removed.

**Fire Safety**

1. Obey the same fire-safety rules you observe when working with hot plates, propane or acetylene torches, soldering irons, and other equipment that operates at extremely high heat.
2. Remove all solids, liquids, and gases that burn easily from the area around the heater.
3. Know where the nearest fire extinguisher is located and how to use it.
4. Know how to put out fire from all the types of material near the heater.

## Section 5 – INSTALLATION

### Unpack and Check for Damage

Remove the Model 4069 heater from its shipping container and associated packaging. Check the unit for any potential damage due to shipping. In the unlikely event damage has occurred, keep all shipping containers and materials in order to file a damage claim with the shipping company responsible for shipping the unit.

### Mounting the Heater

The Model 4069 heater should be mounted to a structure or framework that is designed to support the weight of the heater and provide stability to the unit. There are four 3/8 X 16 threaded holes on each side of the heater for mounting. Mount the heater in an orientation that will allow for the heater to be fully opened (40° maximum) for maintenance, as well as for ease of threading product in continuous process applications. Please refer to Figure 3-1 for product dimensions and mounting information.

In vertical applications, the right side of the heater should be on top for the flow switch to operate correctly. (With the cooling fan positioned toward you the hinge for the heater will be on the left hand side. The heater will hinge open to the left)

*Note: Vertical burn lamps are recommended when operating the Model 4069 in a vertical orientation. All Research Inc. lamps associated with the Model 4069 heater are designed for universal (both horizontal and vertical) operation.*

### Gas Struts

The Model 4069 includes gas struts to assist in opening the Model 4069 heater. The struts also limit the angle to which the heater can be opened to 40 degrees.

*Note: If the heater is used in a vertical operation Gas Struts are not required. A Stop bolt is added to the hinge to limit the opening of the heater. If the heater is relocated to a vertical operation remove one strut, preferably the top strut. The latching strut may be replaced with the non-latching strut if applicable.*

If replacing the struts, orient such that the shafts extend to the bottom of the heater (see Figure 5-1).

**NOTE: FOR SAFETY**, a latching shock is installed on the left side of the model 4069 heater. The latch will prevent the heater from closing should the gas strut fail.

**To Use: When closing the heater, pull the knob to release the latch while closing.**

**Figure 5-1. Gas Strut Orientation**

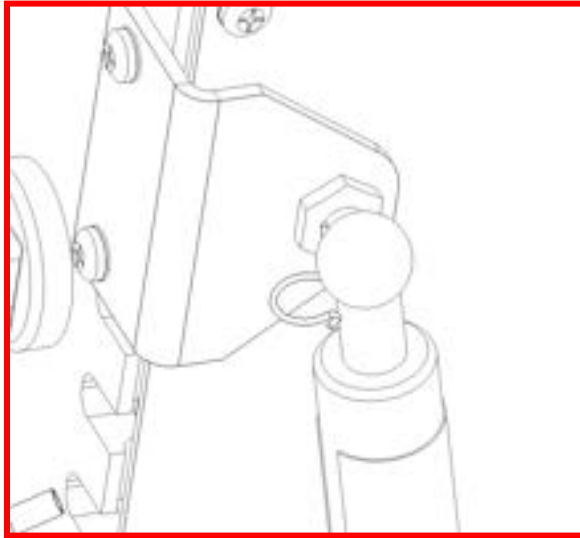

**Figure 5-2. Gas Strut Pin**

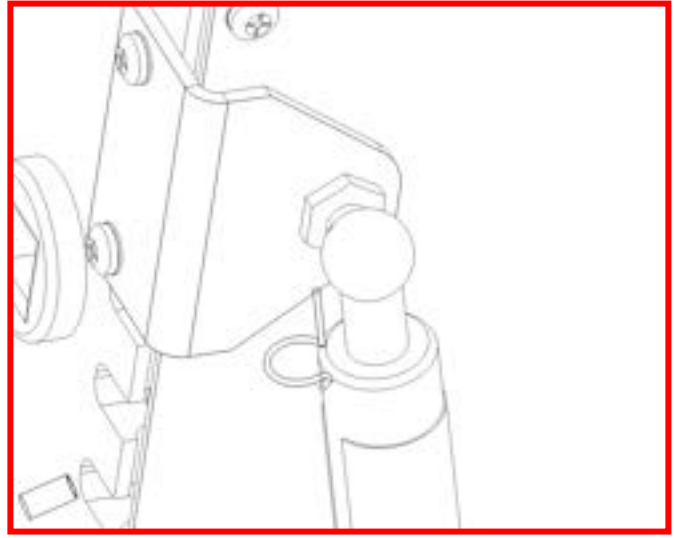

**Figure 5-3. Gas Strut Pin Removal**

### **Heater Cooling Connections**

The highly polished aluminum reflectors require liquid cooling to keep the reflecting surface from overheating. If the reflectors overheat, the surface can become oxidized. When oxidation occurs, the aluminum begins to absorb the energy from the lamps, rather than reflecting it to the product, reducing the efficiency of the heater.

Each Model 4069 is designed with 'quick-disconnect' fittings protruding from the heater cover. There is one inlet and one outlet sized for ½ inch O.D. Nylon 11 flexible tubing (included with heater). Please refer to Specifications for proper water-cooling flow rates.

It is recommended to cool the Model 4069 using a closed-loop cooling system that is sized properly for the size of the heater. The recommended cooling media is clean, de-ionized, or distilled water. A water/glycol solution may also be used if required by the closed loop cooling system.

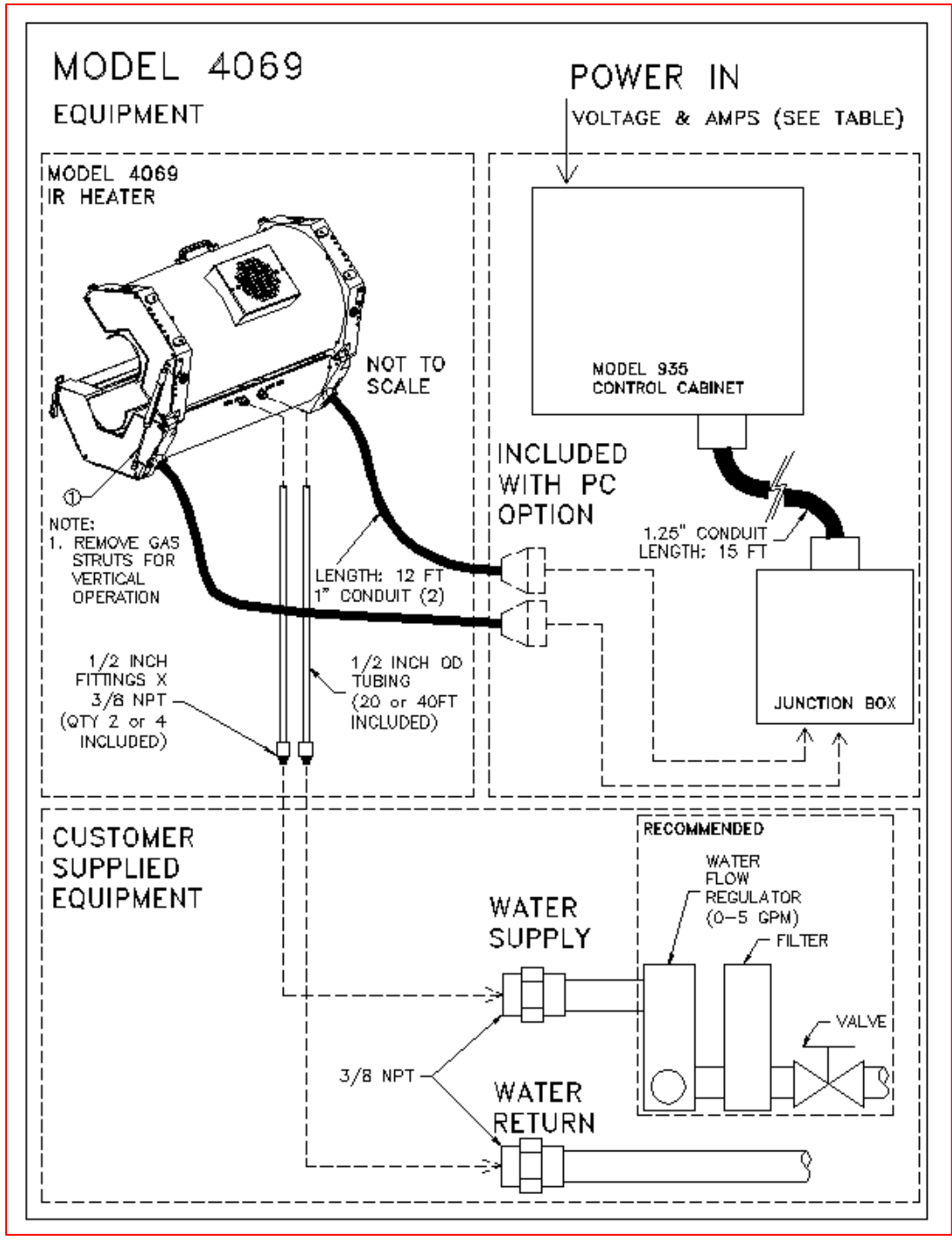

Figure 5-4. Typical Installation



## Electrical Connections

The Model 4069 is supplied with two 12-foot (254 mm) power cable bundles. The cable bundles consist of the power wires for the lamps and fan, as well as control wires for the thermostat (TSTAT), water flow interlock switch (WFIS), and heater open interlock switch (HILS). If the Model 4069 was ordered without the "PC" option, the wires are not terminated into a connector. It is the customer's responsibility to hard wire the heater into the power control system. Wiring diagrams can be found in the Appendix. **Only instructed or skilled persons shall be entrusted with the installation of this heater.**

*Note: The heater should never be directly wired into a voltage source. The heater should always be wired into a power controlling system.*

Model Number	System Voltage (3 phase)	System Amperage
4069-12R-05L-6kW-240V-PC-XX	240	14
4069-12R-05L-6kW-480V-PC-XX	480	7
4069-12R-05L-12kW-240V-PC-XX	240	29
4069-12R-05L-12kW-480V-PC-XX	480	15
4069-12R-10L-12kW-240V-PC-XX	240	29
4069-12R-10L-12kW-480V-PC-XX	480	15
4069-12R-10L-24kW-240V-PC-XX	240	58
4069-12R-10L-24kW-480V-PC-XX	480	29
4069-12R-16L-19kW-240V-PC-XX	240	47
4069-12R-16L-19kW-480V-PC-XX	480	24
4069-12R-25L-30kW-480V-PC-XX	480	37
4069-12R-38L-46kW-480V-PC-XX	480	55
4069-18R-05L-9kW-240V-PC-XX	240	22
#4069-18R-05L-9kW-480V-PC-XX	480	11
4069-18R-05L-18kW-240V-PC-XX	240	44
#4069-18R-05L-18kW-480V-PC-XX	480	22
4069-18R-10L-18kW-240V-PC-XX	240	44
#4069-18R-10L-18kW-480V-PC-XX	480	22
#4069-18R-10L-36kW-480V-PC-XX	480	43
4069-18R-16L-29kW-240V-PC-XX	240	70
#4069-18R-16L-29kW-480V-PC-XX	480	35
4069-18R-25L-45kW-480V-PC-XX	480	55
4069-18R-38L-68kW-480V-PC-XX	480	83

**Table 5-1. Electrical System Requirements**

# Refer to drawing A106827-001 on page 36 of 39 for special wiring instructions of a 240 volt wired heater connected to 480 volts.

### **Thermostat (TSTAT)**

The Model 4069 is supplied with a thermostat (TSTAT) to protect from overheating. The TSTAT protects the heater from overheating only if the TSTAT is properly wired into the control interlock of the power control system. The TSTAT should be wired into a disconnect relay of the power controller/system. If the TSTAT "open" (trips), the disconnect relay of the power control system should remove power to the Model 4609 Heater. The TSTAT is mounted to the backside of the last reflector before the cooling fluid exits the heater. The TSTAT has a fixed trip temperature of 160°F (71.1°C). If the reflector reaches 160°F (71.1°C), the TSTAT will "open" and will not "close" (reset) until it cools down to 130°F (54.4°C).

### **Water Flow Interlock Switch (WFIS)**

Water-cooling is required for proper and safe operation of the Model 4069. The heater is supplied with one or two WFIS to ensure that it has water-cooling going through the reflectors, to protect from overheating. The WFIS protects the heater from overheating only if the WFIS is properly wired into the control interlock of the power control system. The WFIS should be wired into a disconnect relay of the power controller/system. If the WFIS "opens" (trips), the disconnect relay of the power control system should remove power to the heater. The WFIS is plumbed in-line with the cooling line of the last reflector, before the cooling fluid exits the heater. The WFIS has a minimum flow-rate requirement of 0.5 GPM (1.9 LPM). If the liquid cooling flow rate falls below 0.5 GPM (1.9 LPM), the WFIS will "open", and will not "close" if the cooling system fails to provide the minimum 0.5 GPM (1.9 LPM) of cooling fluid. The WFIS is designed to protect the heater if there is a malfunction in the cooling supply. Please refer to Specifications for proper water-cooling rates. Both 25L and 38L lengths are equipped with dual cooling circuits and have two flow switches, one for each circuit.

*Note: Flow switch is packaged internal in all but the 5 and 10-inch length models. For these heaters, it is shipped separately.*

### **Heater "Open" Interlock Switch (HILS)**

It is very dangerous to open the Model 4069 while it is in operation. The heater is supplied with a Heater "Open" Interlock Switch (HILS). The HILS is to protect an operator from the lamps of the heater, if the operator happens to open the heater while it is in operation. The HILS protects the operator only if the HILS is properly wired into the control interlock of the power control system. The HILS should be wired into a disconnect relay of the power controller/system. The HILS is a dry-contact switch mounted in the heater where the two heater halves meet. If the heater is opened while the lamps are on, or if the lamps are in a standby mode, the HILS will "open" (trip), not allowing the lamps to turn on. If the HILS "opens", the disconnect relay of the power control system should remove power to the lamps of the heater.



## Section 6 – MAINTENANCE

The repair and maintenance of the Model 4069 includes replacement of the T3-style lamps, cleaning/replacement of the split quartz liner, and cleaning of the reflectors. **Only instructed or skilled persons shall be entrusted with the maintenance work on this heater.**

**Lamp Removal/Replacement/Installation:** The T3-style lamps are installed into the Model 4069 when shipped from the factory. The following procedure details the process to replace the lamps in the Model 4069 (reference Figure 6-1, 6-2, & 6-3):

*Note:*

- **Only instructed or skilled persons shall be entrusted with the maintenance work on this heater.**
- *Remove all power from the heater BEFORE attempting to install/replace the lamps.*
- *Allow a minimum of 1/2-inch (12 mm) of slack in the lamp leads so that the leads are not taut when inserted into the lamp terminal blocks.*
- *Always take care to handle all lamps by the ceramic end seals and use clean cotton or latex gloves to prevent contamination of the quartz lamp envelopes.*

1. Remove quartz liner (see Section 6.2). Take this opportunity to clean the liner.
2. Remove end-cover screws (4 per end cover).
3. Remove end covers on both ends of the heater.
4. Remove end-reflector screws (2 per reflector)
5. Remove end reflectors on both ends.
6. Remove the lamp wires from the ceramic terminal blocks.
7. Carefully disengage lamp from clips (both ends).
8. Slide the end of the lamp through the rectangular cutout in the end casting on one end of the heater through the rectangular cutout in the end casting of the other end of the heater.

### *Installing new lamp*

9. Position the lamp over the lamp clips so that the lighted portion of the lamp is equally space in the reflector.

*Note: Be sure that the Gas Fill Tip is facing away from the reflector*

10. While holding the lamp on both ends by the ceramic end seals, with light pressure push the lamp into the lamp clips. A slight twisting motion of the lamp, while pushing the lamp into the clip, helps the lamp to seat properly.

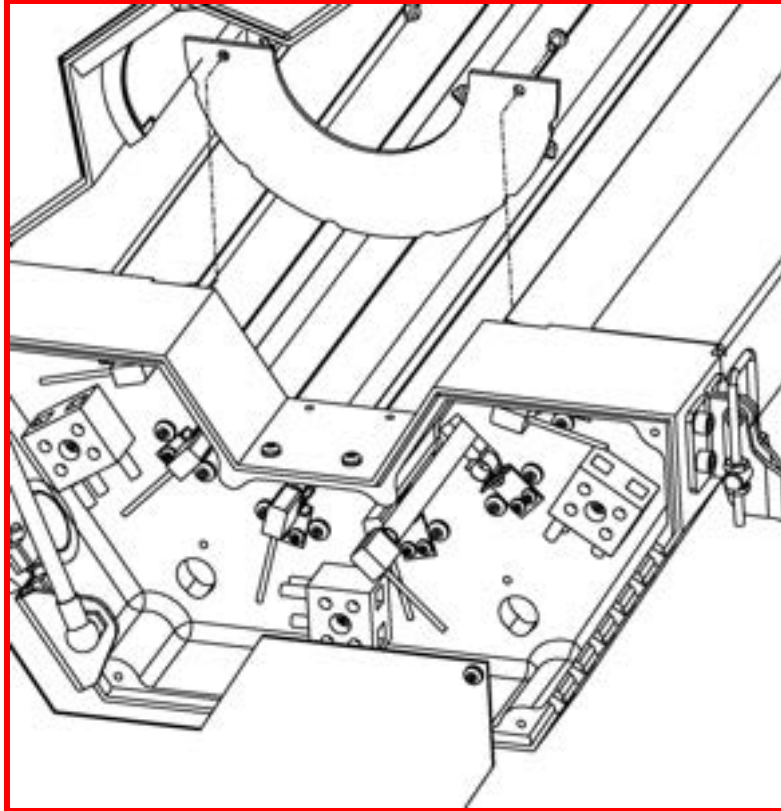

**Figure 6-1. Lamp Installation**

11. Cut wire to a length allowing for a service loop.
12. Strip back the insulation on the end of the lamp leads approximately 1-1/2 inches (38 mm).
13. Insert the bare wire of each insulated lamp lead into the ceramic terminal block position that previously held the old lamp. Push each lead wire into the terminal block far enough so, that when tightened, the setscrew will hold the lead securely.
14. Tighten the setscrews in each terminal block so the lead wires are held securely (1.0 Ft.-Lbs. [1.4 N-m]).
15. Form a loop within each lead along its length. This loop will act as a strain relief within the lead during normal operation of the heater.
16. Reinstall the end reflectors, end covers, and quartz liner.

**Split Quartz Liner Cleaning and Replacement:** The split quartz liner can be replaced or removed from the Model 4069 for periodic cleaning. Use the following procedure to remove/reinstall/clean the quartz liner:

*Note:*

- **Remove all power from the heater BEFORE attempting to install/replace the lamps.**
  - **Always use clean cotton or latex gloves when handling the split quartz liner so as not to deposit any oils or grease from your hands onto the surface of the split quartz liner.**
1. Open the Model 4069 Heater to allow access to each heater half for split quartz liner installation.
  2. Loosen the screws of one liner bracket and slide the bracket away from the quartz-liner of one liner half at one end of the heater, while supporting the liner with other hand.

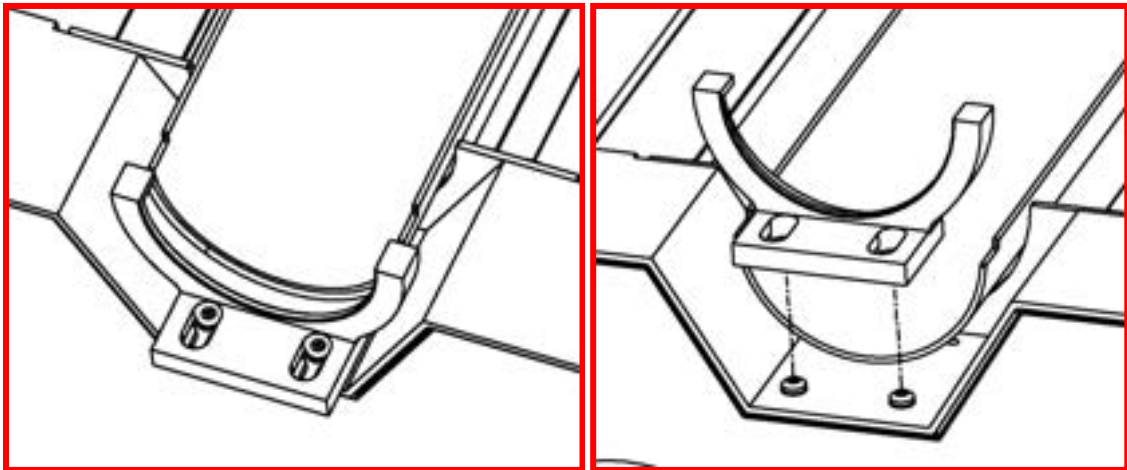

**Figures 6-2 & 6-3. Quartz-Liner Bracket Removal**

3. Remove the bracket from the end casting of the heater.
4. Gently slide the quartz liner out of the grooves of the liner bracket from the opposite end. Take care so that the quartz liner does chip or crack as it is removed.

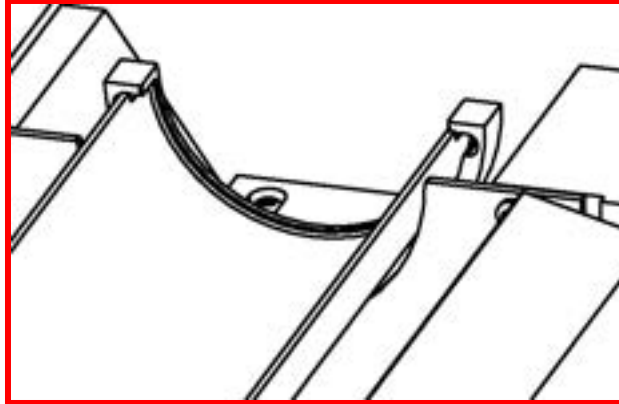

**Figure 6-4. Quartz Liner Removal**

5. If cleaning the liner, use a non-abrasive glass cleaner (i.e. household ammonia and water or isopropyl alcohol) and a clean, dry, lint-free cloth. After cleaning, do not touch the outside surface of the liner unless wearing cotton gloves.
6. Reinsert the edges of the liner into the grooves of the quartz-liner bracket.
7. Reinstall the other bracket and secure with the two bracket screws.
8. Repeat this process for the other half of the liner.

**Cleaning the Reflectors:** Clean reflectors provide the greatest radiant efficiency. If the reflector surface becomes contaminated, it reflects less energy. The energy that is not reflected is lost, absorbed by the reflectors, and removed by the cooling water and air.

The following procedure should be used to clean the Model 4069 reflectors:

*Note:*

- **Only instructed or skilled persons shall be entrusted with the maintenance work on this heater.**
  - ***Remove all power from the heater BEFORE attempting to clean the heater reflectors.***
1. Remove the lamps and quartz liner as described in Section 6.1 – Lamp Removal/Replacement/Installation and Section 6.2 Split Quartz Liner Cleaning and Replacement.
  2. Clean the reflectors with a mixture of warm water and common household ammonia followed by a thorough wipe-down using a clean, water-dampened flannel cloth.
  3. Depending on the type of contamination present on the reflector, a suitable solvent may be required to remove the contamination. The solvent must be selected based on its inability to adversely affect the aluminum reflector.
  4. Thoroughly wipe the reflector using the warm water/household ammonia mixture followed by the dampened flannel cloth.
  5. Replace the lamps and quartz liner, as outlined in Section 6.1 – Lamp Removal/Replacement/Installation and Section 6.2 Split Quartz Liner Cleaning and Replacement.

If necessary, the reflectors may require re-polishing. This is permissible because the reflector is solid aluminum and can be re-polished many times without damage from continued erosion. A fine particle polishing compound, such as a chrome, semi-chrome, or soft metal polishing compound may be used. These types of compounds can be found at a local automotive or metal-polishing supply house. Follow the polishing instructions listed on the polishing product.

The reflectors can be removed from the Model 4069 Heater to make cleaning and maintenance easier. The following procedure should be used to remove the Model 4069 reflectors:

*Note:*

- **Only instructed or skilled persons shall be entrusted with the maintenance work on this heater.**
  - ***Remove all power from the heater BEFORE attempting to install/replace the heater reflectors.***
1. Drain all cooling fluid from the heater and blow out the heater cooling lines with compressed air.
  2. Remove the heater-cover screws and heater cover.

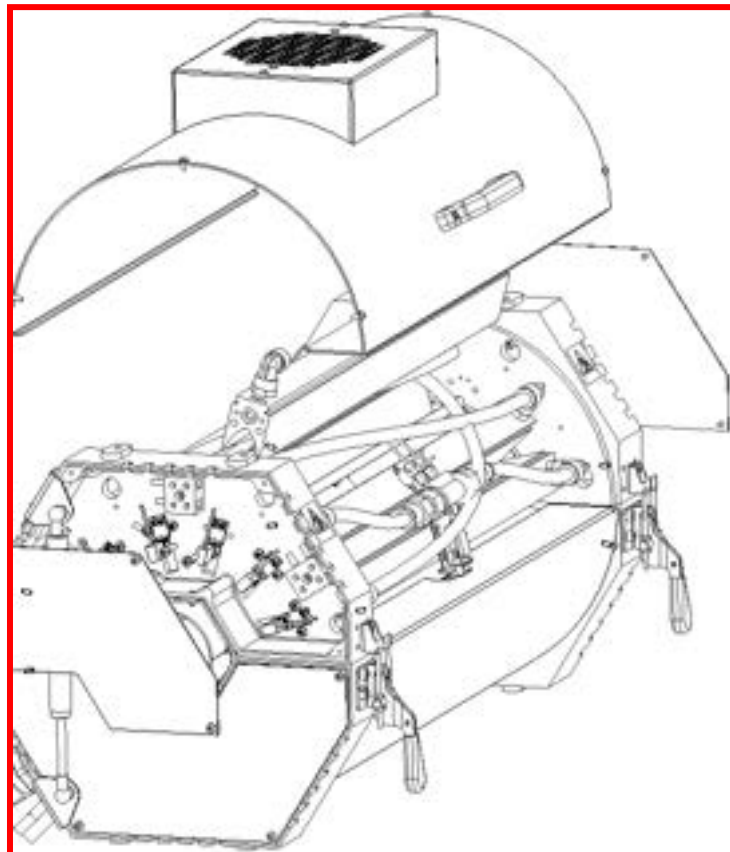

**Figure 6-5. Heater Cover Removal**



3. Disconnect the cooling line from the reflector to be maintained.
4. Loosen all screw from all reflectors on one side of the end casting of the reflector to be maintained.
5. Remove the reflector mounting screws from the end casting of the reflector to be maintained.
6. Remove the reflector.

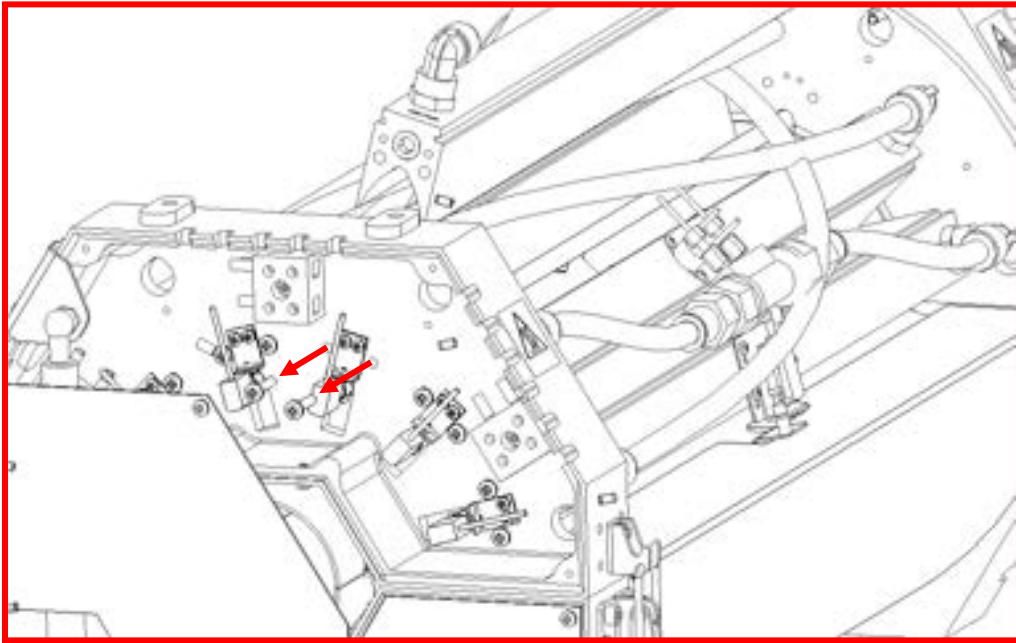

**Figure 6-6. Reflector Removal**

## Section 7 – SPARE & REPLACEMENT PARTS

Replacement parts for the Model 4069 are listed below. Reference Figures 7-1 through 7-6 when using this list.

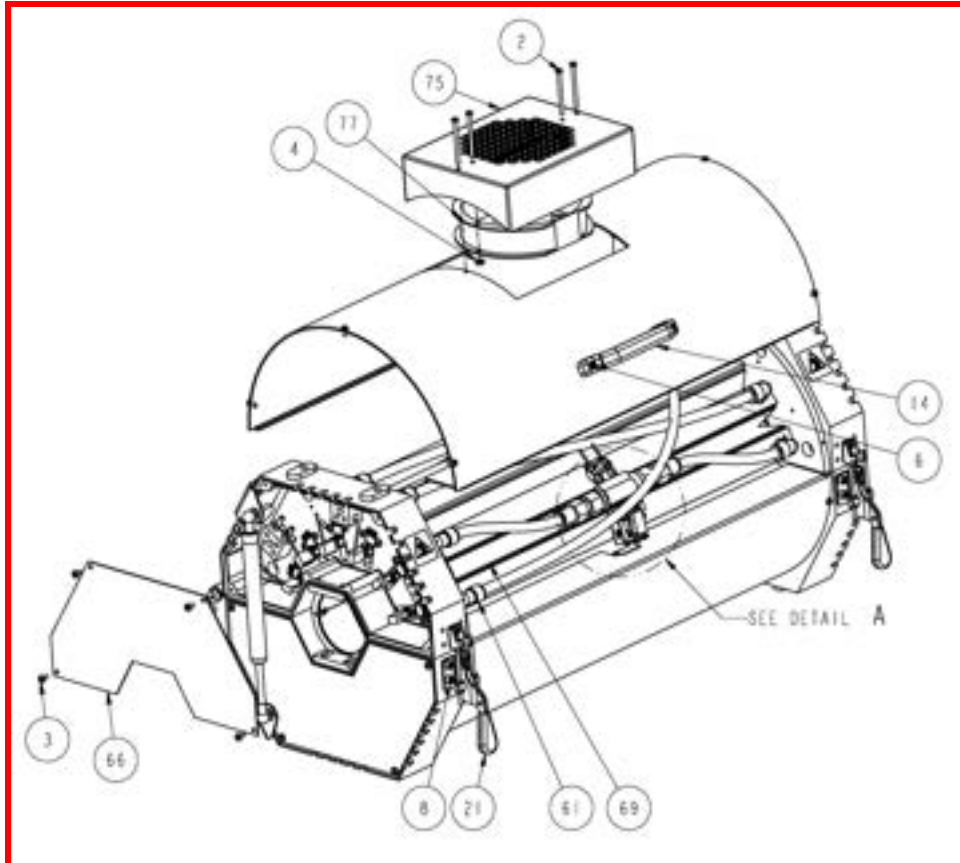

Figure 7-1.

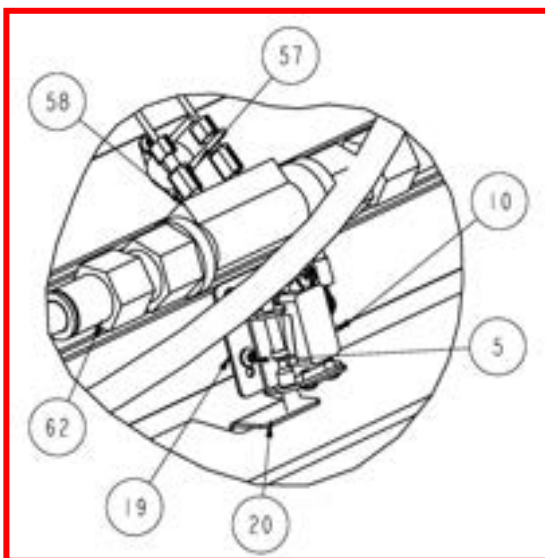

Figure 7-2.

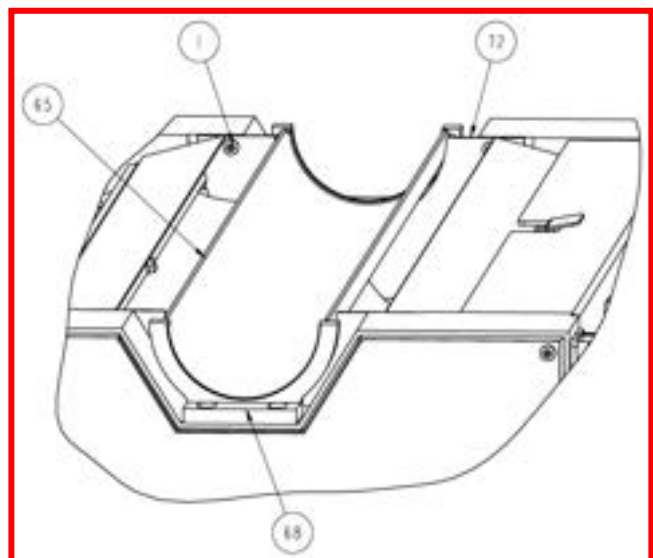

Figure 7-3.

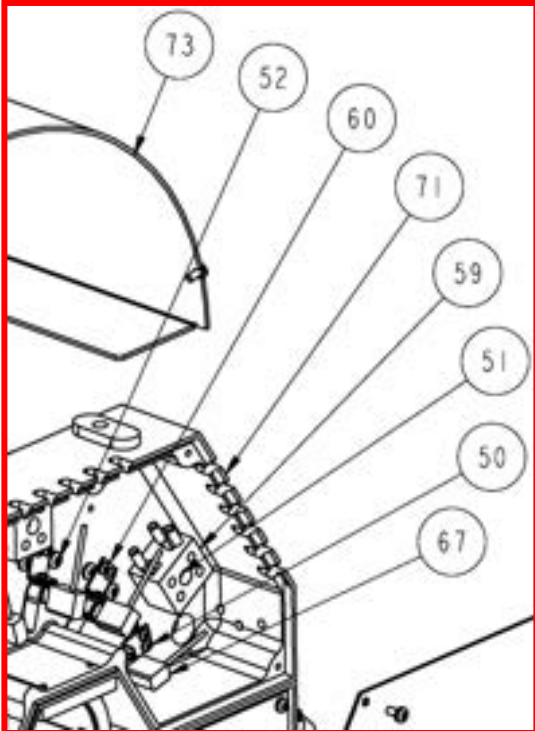

Figure 7-4.

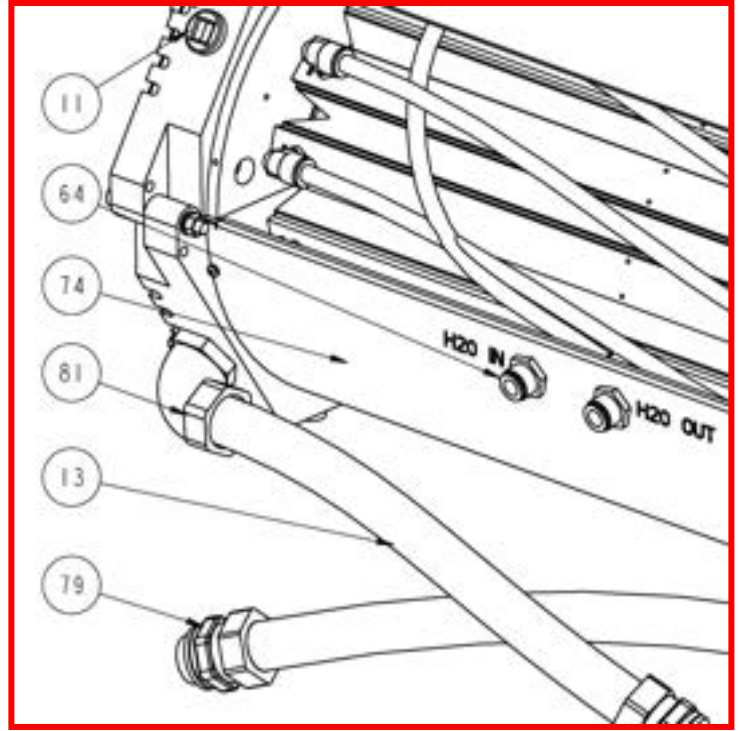

Figure 7-5.

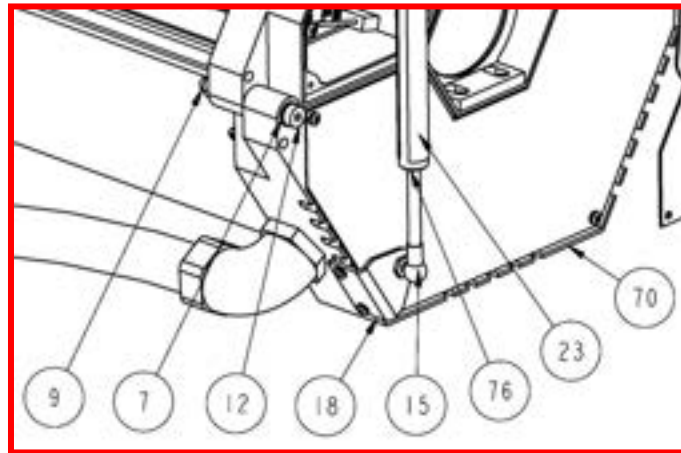

Figure 7-5.

<b>Figure 7-6. PARTS LIST FOR THE 4069</b>			12 Reflector					18 Reflector				
Item	Part Number	Description	5L	10L	16L	25L	38L	5L	10L	16L	25L	38L
1	054979-077	Screw, Panhead 8-32x5/16 Sst Ph	8	8	8	8	8	8	8	8	8	8
2	054979-086	Screw, Panhead 8-32x2-1/4 Sst Ph	4	4	4	4	4	4	4	4	4	4
3	054979-097	Screw, Panhead 8-32x3/8 Ph Sems Int	44	44	44	44	44	44	44	44	44	44
4	054982-005	Nut-Kep 10-32 Nc Zinc	2	2	2	2	2	2	2	2	2	2
5	055000-009	Screw-Sm Ph6-32x1/4t23 Cad Ph	6	6	6	6	6	6	6	6	6	6
6	055020-082	Screw, Flathead 8-32x3/4 Sst Ph(82)	2	2	2	2	2	2	2	2	2	2
7	055029-048	Washer-Flat,.39idx.625x.057,Ss	4	4	4	4	4	4	4	4	4	4
8	055296-064	Screw-Socket 1/4-20x1/2,Sst	12	12	12	12	12	12	12	12	12	12
9	055452-003	Nut-Hex Nylock 5/16-18	2	2	2	2	2	2	2	2	2	2
10	055959-000	Switch-Leaf Act Spdt H/S	1	1	1	1	1	1	1	1	1	1
11	057885-001	Plug-Pipe,1" Npt	2	2	2	2	2	2	2	2	2	2
12	064704-009	Screw-Shoulder .375x2.50 Skt Hd	2	2	2	2	2	2	2	2	2	2
14	100441-001	Handle-Stainless Stl,5.359	1	1	1	1	1	1	1	1	1	1
15**	102423-001	Ball End Socket	4	4	4	4	4	4	4	4	4	4
18	106090-001	Bracket-Angle Ball Stud,10mm	4	4	4	4	4	4	4	4	4	4
19	106647-001	Bracket Switch,M4069	1	1	1	1	1	1	1	1	1	1
20	106648-001	Bracket Switch Actuator,M4069	1	1	1	1	1	1	1	1	1	1
21	106782-001	Latch-Draw,5in,700lb	2	2	2	2	2	2	2	2	2	2
23**	106793-001	Gas Strut Shield , 2"X6"L	2	2	2	2	2	2	2	2	2	2
50	054979-041	Screw, Panhead 6-32x3/16 Sst Ph	50	50	50	50	50	74	74	74	74	74
51	054979-082	Screw, Panhead 8-32x1 Sst Ph	12	12	12	12	12	20	20	20	20	20
52	054979-112	Screw, Panhead 10-32x1 Sst Ph	48	48	48	48	48	72	72	72	72	72
57	070025-015	Thermostat NC 160F	1	1	1	2	2	1	1	1	2	2
58***	099655-001	Flow Switch	1	1	1	2	2	1	1	1	2	2
59	100571-003	Terminal Block Ceramic 2p 30a	12	12	12	12	12	18	18	18	18	18
60	103884-001	Lamp Spring Clip	24	24	24	24	24	36	36	36	36	36
61	104358-001	Fitting-Elbow,3/8 NPT,1/2 inch Tube	24	24	24	24	24	36	36	36	36	36
62***	104399-002	Fitting-Str,1/2 inch tube,1/2 NPT,Female	2	2	2	4	4	2	2	2	4	4
63	104431-002	Nylon Tubing -1/2 inch OD	17	17	23	32	45	22	22	31	44	64
64	106789-003	Fitting-Bulkhead,Elbow,1/2 inch tube	2	2	2	4	4	2	2	2	4	4
65	106895-009	Split Quartz Liner for 4069-12-05	2									
	106895-001	Split Quartz Liner for 4069-12-10		2								
	106895-002	Split Quartz Liner for 4069-12-16			2							
	106895-003	Split Quartz Liner for 4069-12-25				2						
	106895-004	Split Quartz Liner for 4069-12-38					2					
	106895-010	Split Quartz Liner for 4069-18-05						2				
	106895-005	Split Quartz Liner for 4069-18-10							2			
	106895-006	Split Quartz Liner for 4069-18-16								2		
	106895-007	Split Quartz Liner for 4069-18-25									2	
106895-008	Split Quartz Liner for 4069-18-38										2	
66	103345-002	End Cover for 4069-12-XX	4	4	4	4	4					
	103345-003	End Cover for 4069-18-XX						4	4	4	4	4
67	103390-001	Lamp - 500W, 120V, Ceramic Endseal	12*					18*				
	103390-002	Lamp - 1000W, 240V, Ceramic Endseal	12*					18*				
	103390-003	Lamp - 1000W, 240V, Ceramic Endseal		12*					18*			
	103390-004	Lamp - 2000W, 240V, Ceramic Endseal		12*					18*			
	103390-005	Lamp - 1600W, 240V, Ceramic Endseal			12*					18		
	103390-007	Lamp - 2500W, 480V, Ceramic Endseal				12					18	
	103390-010	Lamp - 3800W, 480V, Ceramic Endseal					12					18
68	106850-001	Quartz Window Clip for 4069-12-XX	4	4	4	4	4					
	106850-002	Quartz Window Clip for 4069-18-XX						4	4	4	4	4
69	106721-015-A	Reflector for 4069-XX-05	12					18				
	106721-001-A	Reflector for 4069-XX-10		12					18			
	106721-002-A	Reflector for 4069-XX-16			12					18		
	106721-003-A	Reflector for 4069-XX-25				12					18	
	106721-004-A	Reflector for 4069-XX-38					12					18

<b>Figure 7-6. PARTS LIST FOR THE 4069</b>			12 Reflector					18 Reflector				
Item	Part Number	Description	5L	10L	16L	25L	38L	5L	10L	16L	25L	38L
70	106776-001	Machined End Cast,A for 4069-12-XX	2	2	2	2	2					
	106776-002	Machined End Cast,A for 4069-18-XX						2	2	2	2	2
71	106777-001	Machined End Cast,B for 4069-12-XX	2	2	2	2	2					
	106777-002	Machined End Cast,B for 4069-18-XX						2	2	2	2	2
72	106778-001	End Reflector for 4069-12-XX	4	4	4	4	4					
	106778-002	End Reflector for 4069-18-XX						4	4	4	4	4
73	106779-005	Top Cover for 4069-12-05	1									
	106779-001	Top Cover for 4069-12-10		1								
	106779-002	Top Cover for 4069-12-16			1							
	106779-003	Top Cover for 4069-12-25				1						
	106779-003	Top Cover for 4069-12-38					1					
	106718-005	Top Cover for 4069-18-05						1				
	106718-001	Top Cover for 4069-18-10							1			
	106718-002	Top Cover for 4069-18-16								1		
	106718-003	Top Cover for 4069-18-25									1	
106718-004	Top Cover for 4069-18-38										1	
74	106780-005	Bottom Cover for 4069-12-05	1									
	106780-001	Bottom Cover for 4069-12-10		1								
	106780-002	Bottom Cover for 4069-12-16			1							
	106780-003	Bottom Cover for 4069-12-25				1						
	106780-004	Bottom Cover for 4069-12-38					1					
	106719-005	Bottom Cover for 4069-18-05						1				
	106719-001	Bottom Cover for 4069-18-10							1			
	106719-002	Bottom Cover for 4069-18-16								1		
106719-003	Bottom Cover for 4069-18-25									1		
106719-004	Bottom Cover for 4069-18-38										1	
75	106781-001	Fan Housing, 4069-12-XX		1	1	1	1					
	106781-002	Fan Housing, 4069-18-XX						1	1	1	1	1
	106781-003	Fan Housing, 4069-12-05	1									
	106781-004	Fan Housing, 4069-18-05						1				
76**	106783-011	Gas Spring for 4069-12-10		1								
	107358-011	Gas Spring for 4069-12-10 w/safety Latch		1								
	106783-012	Gas Spring for 4069-12-16			1							
	107358-012	Gas Spring for 4069-12-16 w/safety Latch			1							
	106783-013	Gas Spring for 4069-12-25				1						
	107358-013	Gas Spring for 4069-12-25 w/safety Latch				1						
	106783-014	Gas Spring for 4069-12-38					1					
	107358-014	Gas Spring for 4069-12-38 w/safety Latch					1					
	106784-011	Gas Spring for 4069-18-10						1				
	107396-011	Gas Spring for 4069-18-10 w/safety Latch						1				
	106784-012	Gas Spring for 4069-18-16								1		
	107396-012	Gas Spring for 4069-18-16 w/safety Latch								1		
	106784-013	Gas Spring for 4069-18-25									1	
	107396-013	Gas Spring for 4069-18-25 w/safety Latch									1	
106784-014	Gas Spring for 4069-18-38										1	
107396-014	Gas Spring for 4069-18-38 w/safety Latch										1	
77	106791-001-A	Fan-260cfm,24vdc		1	1	1	1		1	1	1	1
	106791-002	Fan-260cfm,24vdc, 5 inch	1					1				
79	083314-002	Connector-Flex Conduit Straight 1.00in	2	2	2	2	2	2	2	2	2	2
80	083310-002	Conduit- 1" (12 ft ea)	24 ft	24 ft	24 ft	24 ft	24 ft	24 ft	24 ft	24 ft	24 ft	24 ft
81	083313-002	Connector-Flex Conduit 90deg 1.00in	2	2	2	2	2	2	2	2	2	2

\* Only one set of lamps needed for each heater. Please consult factory if lamp type is not known.

\*\* Item #76 is a replacement assembly consisting of Items 76,15, and 23 (Gas Strut, Ball End Socket, & reflective shield).

\*\*\*Item 58 is a replacement assembly consisting of Items 58 and 64 (Flow switch and fittings)



**SCHEMATIC 12 REFLECTOR**  
(INPUT VOLTAGE = LAMP VOLTAGE)

**FOR USE WITH MODELS:**  
 12R-05L-12KW-240V  
 12R-10L-12KW-240V  
 12R-10L-24KW-240V  
 12R-16L-19KW-240V  
 12R-16L-38KW-384V  
 12R-25L-30KW-480V  
 12R-38L-46KW-480V

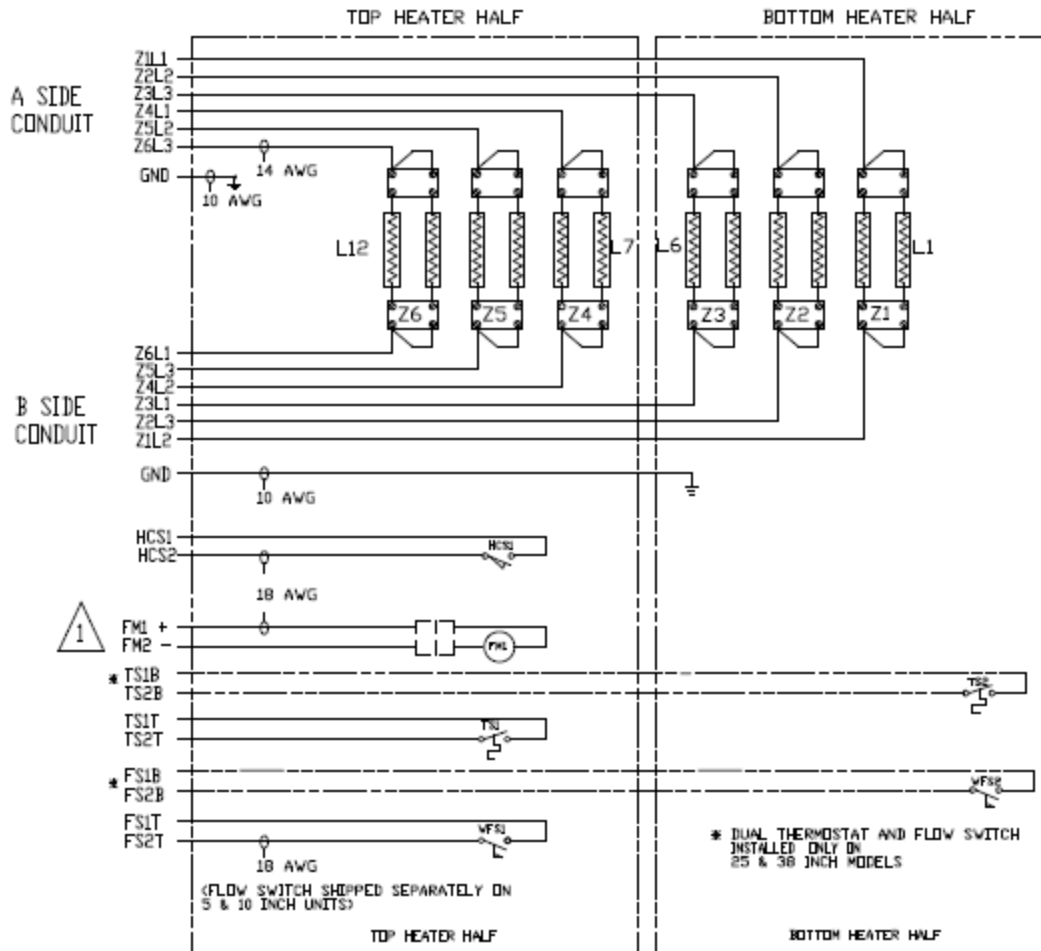

**NOTES:**

1. ADD APPROPRIATE VOLTAGE LABEL TO FAN WIRE (24VDC OR 115VAC)
2. WIRE LENGTH

- =====
- \* STD 4069 W/CONDUIT = 12FT CONDUIT + 2FT EXTRA
  - \* 106796-XXX MODELS W/O CONDUIT = 10FT OUTSIDE END CASTINGS)
  - \* 4069E, 4069P = 3FT CONDUIT PER SIDE, 8' WIRE ON 'A' SIDE 10'4" WIRE ON 'B' SIDE

RESEARCH INC.	
DIAGRAM-WIRING, PLUMB, 4069	
REV A	106682-003
REV NONE	106682-003
SHEET 2 OF 6	

# SCHEMATIC 12 REFLECTOR

INPUT VOLTAGE = 2 X LAMP VOLTAGE

FOR USE WITH MODELS

=====

12R-05L-12KW-480V  
 12R-10L-12KW-480V  
 12R-10L-24KW-480V  
 12R-16L-19KW-480V

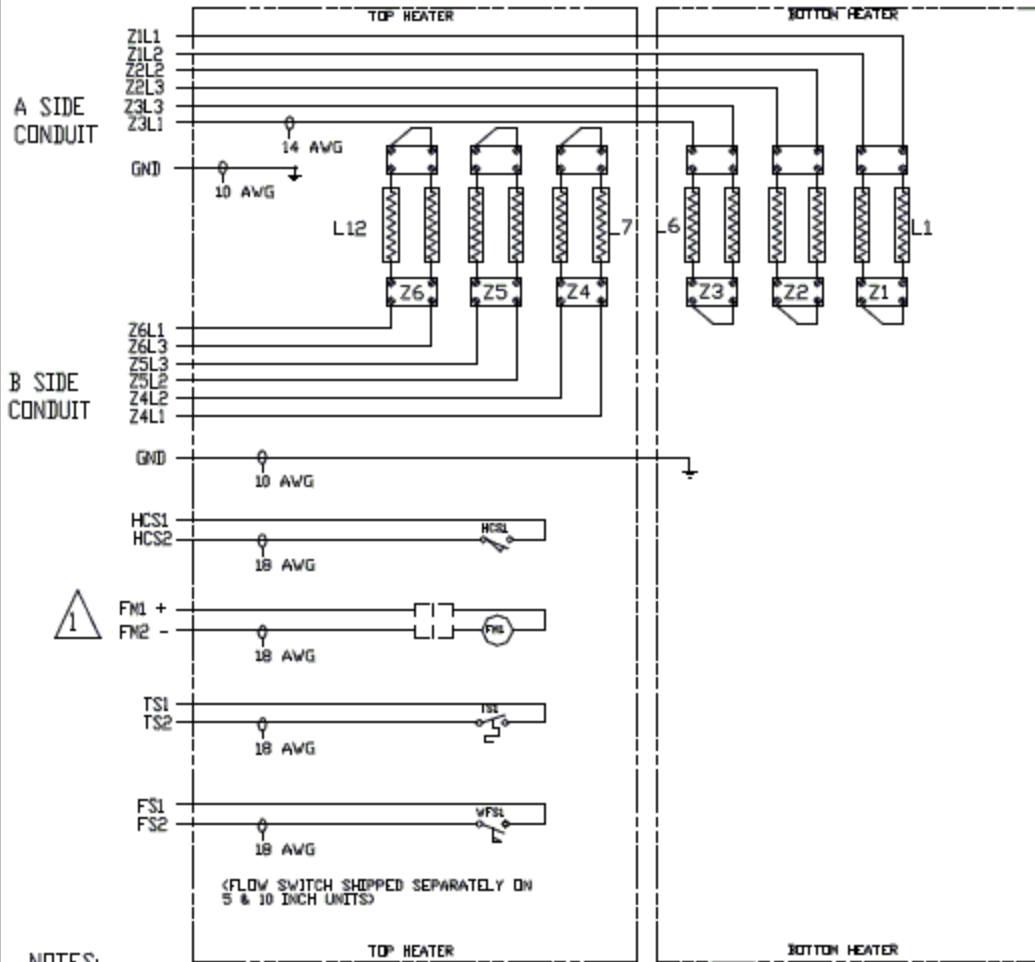

NOTES:

1. ADD APPROPRIATE VOLTAGE LABEL TO FAN WIRE (24VDC OR 115VAC)

2. WIRE LENGTH

- =====
- \* STD 4069 W/CONDUIT = 12FT CONDUIT + 2FT EXTRA
  - \* 106796-XXX MODELS W/O CONDUIT = 10FT OUTSIDE END CASTINGS)
  - \* 4069E, 4069P = 3FT CONDUIT PER SIDE, 8' WIRE ON 'A' SIDE 10'4" WIRE ON 'B' SIDE

RESEARCH INC.		RESEARCH, CANTON, OHIO	
DIAGRAM-WIRING, PLUMB, 4069			
REV	REV. NO.	REV. DATE	REV. NO.
A	106682-003	106682-003	9
REV	0204	SHEET 3 OF 6	



# SCHEMATIC 18 REFLECTOR

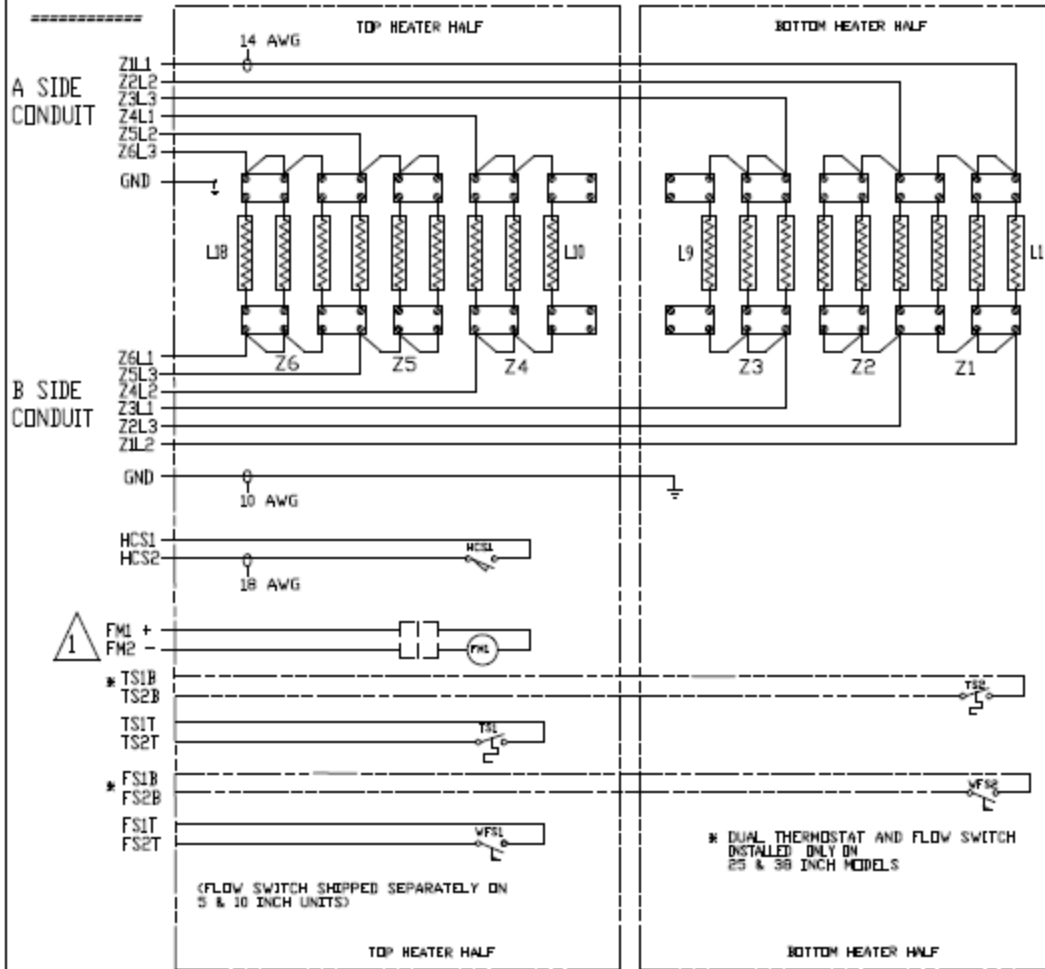

**NOTES:**

1. ADD APPROPRIATE VOLTAGE LABEL TO FAN WIRE (24VDC OR 115VAC)

2. WIRE LENGTH

- \* STD 4069 W/CONDUIT = 12FT CONDUIT + 2FT EXTRA
- \* 106796-XXX MODELS W/D CONDUIT = 10FT OUTSIDE END CASTINGS)
- \* 4069E, 4069P = 3FT CONDUIT PER SIDE, 8' WIRE ON "A" SIDE 10'4" WIRE ON "B" SIDE

RESEARCH INC.	
DIAGRAM-WIRING, PLUMB, 4069	
REV A	106682-003
DATE 02/04	106682-003 9
SHEET 4 OF 6	

# Refer to drawing A106827-001 on page 36 of 39 for special wiring instructions of a 240 volt wired heaters connected to 480 volts.

# LAMP POSITION CONVENTIONS

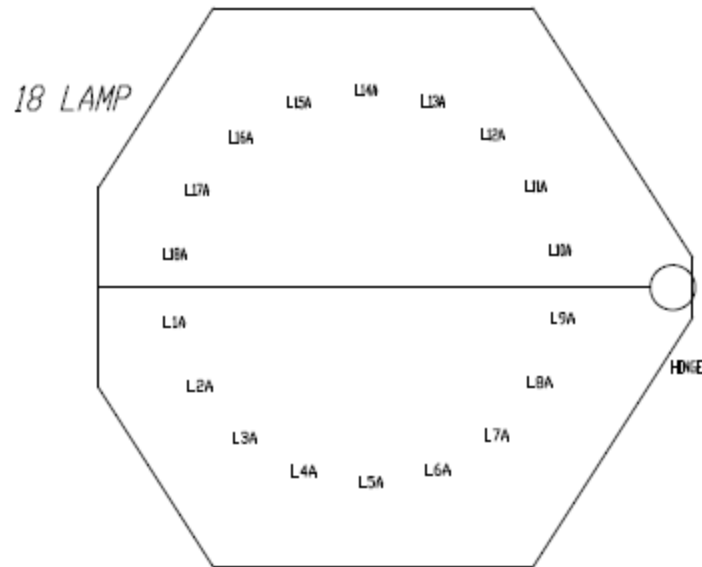
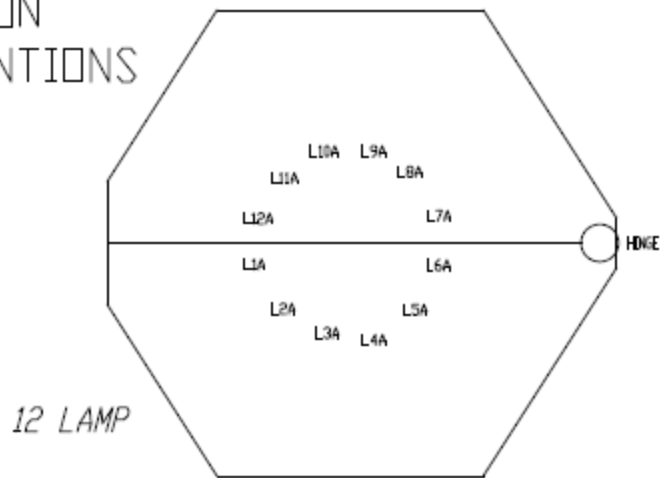

SIDE SHOWN IS "A" END  
 OPPOSITE SIDE IS "B"  
 SIDE

RESEARCH INC.		RESEARCH COMPANY, INC.
DIAGRAM-WIRING, PLUMB, 4069		
REV	DATE	ISSUE
A	106682-003	106682-003
REV	0204	SHEET 5 OF 6

# FLUID FLOW CHART

REFER TO PREVIOUS SHEET  
FOR NUMBERING CONVENTIONS

MODEL	WATER IN		WATER OUT		FLOW SWITCH BETWEEN REFL#'S	TSTAT REFL #
	REFL #	SIDE	REFL #	SIDE		
12-05	1	A	12	B	SHIPPED SEPARATELY	11
12-10	1	A	12	B	SHIPPED SEPARATELY	11
12-16	1	A	12	B	#11 & #12 **	11
12-25 BOTTOM	1	A	6	B	#5 & #6 **	5
12-25 TOP	7	A	12	B	#11 & #12 **	11
12-38 BOTTOM	1	A	6	B	#5 & #6 **	5
12-38 TOP	7	A	12	B	#11 & #12 **	11
18-05	1	A	18	B	SHIPPED SEPARATELY	17
18-10	1	A	18	B	SHIPPED SEPARATELY	17
18-16	1	A	18	B	#17 & #18 **	16
18-25 BOTTOM	1	A	9	B	#8 & #9 **	8
18-25 TOP	10	A	18	B	#17 & #18 **	17
18-38 BOTTOM	1	A	9	B	#8 & #9 **	8
18-38 TOP	10	A	18	B	#17 & #18 **	17

\*\* FLOW SWITCH NOT USED ON ALL 106795-XXX, 106796-XXX UNITS.

 RESEARCH INC. <small>RESEARCH, INCORPORATED</small>			
DIAGRAM-WIRING, PLUMB, 4069			
REV A	REV. DATE 106682-003 0204	PRINT DATE 106682-003	REV 9
		SHEET 6 OF 6	

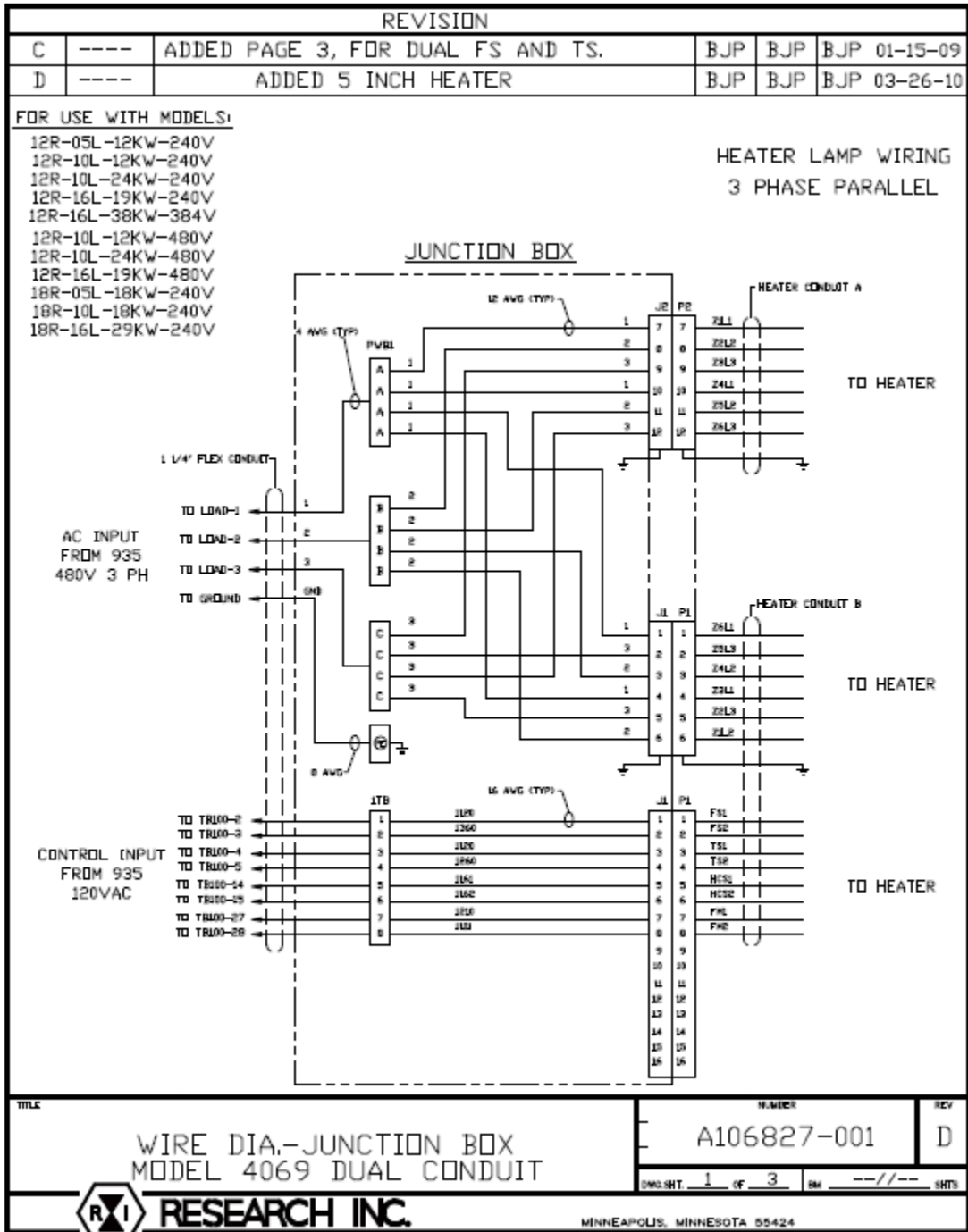

## 240 VOLT HEATERS CONNECTED TO 480 VOLTS

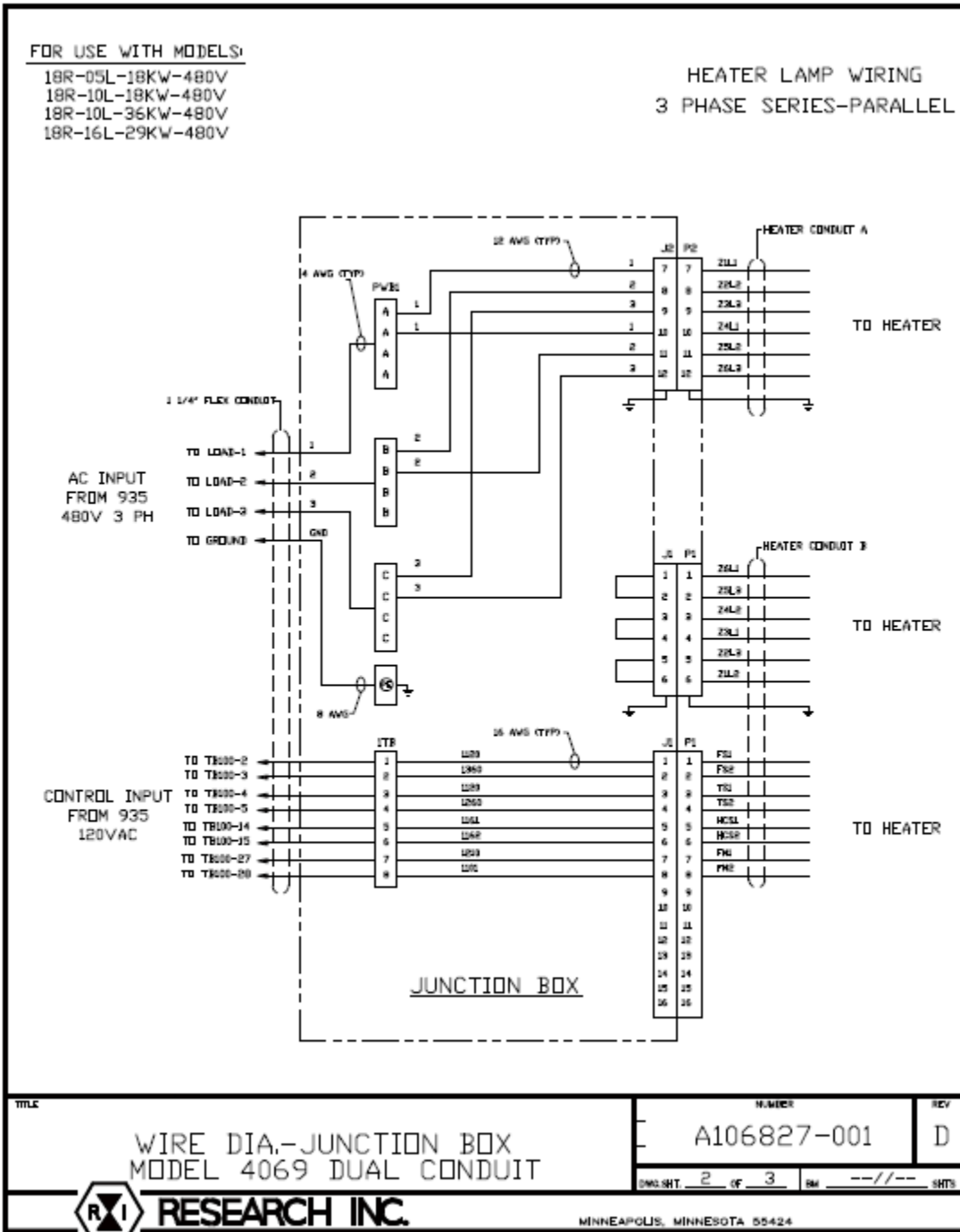

REVISION

FOR USE WITH MODELS:

12R-25L-30KW-480V-PC  
 12R-38L-46KW-480V-PC  
 18R-25L-45KW-480V-PC  
 18R-38L-68KW-480V-PC

HEATER LAMP WIRING  
 3 PHASE PARALLEL  
 (HEATERS WITH 2 TS AND 2 FS)

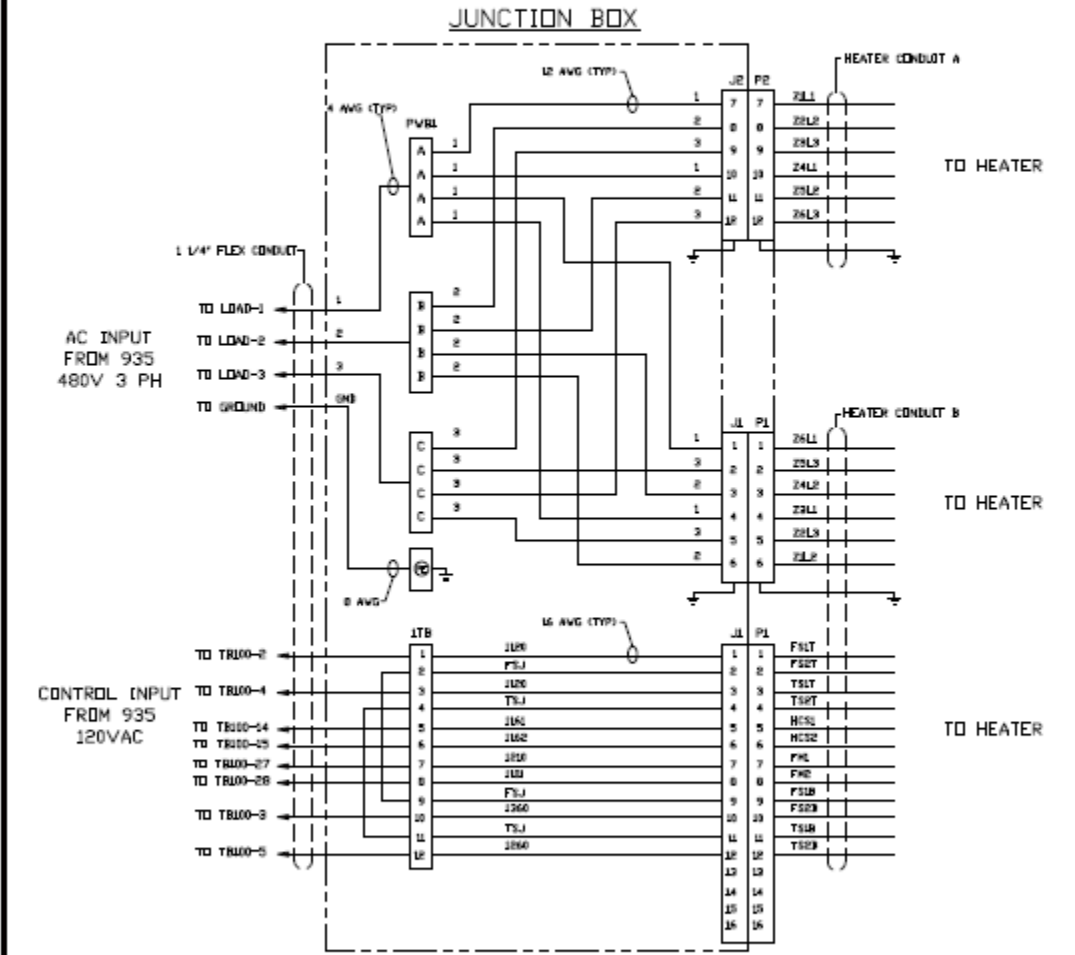

TITLE		NUMBER		REV
WIRE DIA.-JUNCTION BOX MODEL 4069 DUAL CONDUIT		A106827-001		D
SHEET		OF	DATE	BY
3		3	---	---

**RESEARCH INC.**  
 MINNEAPOLIS, MINNESOTA 55424



The 4069 ChamberIR heater has been tested to the EN 60519-2 CE Safety in Electro heat Installations standard.

## CE Compliance

Conditions of acceptability:

1. The IR heater must never be directly wired to a voltage source but must be wired to a power control system, meeting the requirements of EN 60519-2.
2. This power control system shall disconnect power to the IR heater when any of the following conditions occur:
  - a. The cooling flow Sensor switch contact opens indicating a loss of cooling.
  - b. The over temperature thermo-switch contacts open indicating an over-temp condition.
  - c. The IR heater interlock switch opens indicating the heater has been opened.
3. Cooling water at 32°C or less must be provided at the flow rates listed in the product information table on [page 3](#).
4. Provision for a main supply disconnect must be provided at installation.
5. Over current protection is to be provided in the control system or in the final installation as required in EN 60519-2
6. A separate power source is to be provided for the air cooling fan (115Vac or 24Vdc).
7. The conductor identification is to be in accordance with IEC 60204-1 and IEC 60446.
8. Devices for emergency switching off shall be in accordance with of IEC 60204-1 to be provided in installation
9. Steps shall be taken to ensure that interconnecting conductors in normal operating conditions undergo no abnormal mechanical stresses involving tension, flexing, torsion, friction or vibration, or effect of heat, moisture or vapors liable to damage them.
10. The installation is to meet the requirements of IEC 60204-1, IEC 60364-4-41 and EN 60519-2.
11. All positions of the actuating and control devices shall be clearly indicated by letters, words, numbers or symbols, Preference should be given to the use of standard symbols given in IEC 60417-1, IEC 60417-2 and ISO 7000.
12. The completed system is to be subjected to a dielectric test as described in EN 60519-2.
13. The IR heater is to be installed in a system which is supervised, inspected and maintained so that it remains in compliance with EN 60519-2.
14. The IR heater is to be installed in a system in which, precautions shall be taken to ensure that there is no risk to personnel while defects are being remedied as required by EN 60519-2.
15. The IR heater was evaluated for use in a system which is compliant to EN 60519-2.

---

## *Declaration of Incorporation*

EN 60519-2

**Designation:** Model 4069 Infrared Chamber Heater

**Classification:** Industrial Heating Equipment

Meets the essential requirements of the following European Union Directives using the relevant sections of the standards and related documents shown:

### **Low Voltage Directive 2006/95/EC**

Essential health and safety requirements relating to electrical equipment designed for use within certain voltage limits. **Rated Voltage:** 0 - 480 VAC **Rated Frequency:** 50/60 Hz

**EN 60519-2:2006** in conjunction with **EN 60519-1:2003** \_\_\_\_ Safety in Electroheat Installations

**This equipment is not to be put into service until the machinery into which it is to be incorporated has been declared in conformity with the provisions of the European Union Directives.**

**If this product is installed or used in any manner that is inconsistent with the supplied documentation or warnings and labels applied to the equipment then this declaration is invalid and no liability is assumed by the manufacturer.**

**Date of Assessment:** March 2010

**Responsible Corporate Officer:** Terry Nigon

**Date:** 10 March 2010 **Title:** President