

## Model 4555 User's Manual



Publication #: 107679-001 Rev. A

July 2005

Another quality product from:



7128 Shady Oak Road, Eden Prairie, MN 55344

Phone: (952) 949-9009 Fax: (952) 949-9559

E-mail: [info@researchinc.com](mailto:info@researchinc.com)

[www.researchinc.com](http://www.researchinc.com)

Dear Valued Customer:

Thank you for purchasing a Model 4555 PanelIR<sup>®</sup> Infrared Pyropanel. We believe it is the finest system of its type and are confident you will think so too.

For technical assistance, training, replacement parts and assemblies, or any other problems or questions, contract our Field Service specialists. They will do everything they can to help you or will put you in touch with someone who can.

This instruction manual has been carefully prepared to make sure you get out of your system all of the capabilities we designed and built into it. To tell us how we could make the system, our support of it, or this manual even more useful, we invite you to call our product manager with your suggestions and recommendations.

Additional copies of this manual are available at reasonable cost from our Customer Service Department. Once again, let us welcome you to the growing family of Research, Inc. customers. We look forward to working with you in the future.

**Requirement**

Additional information regarding application of the Model 4555 system or other Research Inc. products.

Ordering additional Research Inc. products or Manuals.

Technical assistance and training.

**Appropriate Contact**

Your local sales representative.

Your local sales representative or  
Research, Inc. Customer Service (952) 940-9009

Research Inc. Factory Service  
(952) 949-9009

Sincerely,

Terry Nigon  
President  
Research Inc.

<b><u>Section</u></b>	<b><u>Page</u></b>
<b>SAFETY</b> .....	1
<b>PRODUCT DESCRIPTION</b> .....	2
Dimensions.....	7
<b>INSTALLATION</b>	
Mechanical Installation.....	11
Electrical Installation.....	12
Single Phase Wiring.....	14
Three Phase Wiring.....	15
Lamp Installation.....	19
Thermostat Wiring.....	20
Pressure Switch Wiring.....	20
Blower Wiring.....	21
<b>OPERATING INSTRUCTIONS</b> .....	22
<b>MAINTENANCE INSTRUCTIONS</b> .....	23
<b>Appendix A Multiple Heater Wiring</b> .....	24

# Safety

## General

The Model 4555 Heater is designed for safe operation. Nevertheless, installation, maintenance, and operation of the heater can be dangerous for a careless operator or maintenance person. For your safety and the safety of others, read the instructions in this manual and follow these warnings to help prevent accident or injury.

## Electrical Safety

Due to high voltages present in typical Model 4555 installations there is danger of electrical shock when installing, operation, or servicing the heater. Exercise extreme caution when handling or working with these high voltages.

All applicable local and national electrical codes should be followed to ensure proper installation and operation of the Model 4555. A safe electrical ground must also be provided and properly installed on the heater before attempting to operate the unit.

### **WARNING!**

**Power lines and any other affiliated heater circuitry (i.e., blowers, thermostat, etc.) must be disconnected prior to any servicing issue including lamp installation and change out.**

**The Model 4555 heater should never be operated with the end covers of the heater removed.**

**The presence of open load-to-ground must be verified after lamp installation into the Model 4555 and before system power is applied.**

## Heater Safety

Certain areas of the Model 4555 heater may exceed 500° F (260° C) while the heater is in operation. Exercise extreme care when working in close proximity to an operating heater.

### **WARNING!**

NEVER place any part of the body under or near any part of the heater while power is applied.

Always allow the heater to cool sufficiently (at least 5 minutes with the blower operating, longer if the blower is not operating) before servicing any part of the heater, including lamps or adjacent parts.

## Infrared Radiation

**CAUTION!** Continuous exposure to high-intensity infrared radiation at close proximity could be harmful to eyes or skin. Although infrared lamps emit negligible ultra violet electromagnetic radiation, harmful burns can still result if an operator is in close contact with lamps being operated at high intensity.

Because of the brilliant light emitted by infrared lamps at full intensity, it is recommended that eyes be shielded from the glare if observing the lamps for an extended period of time. Use suitable shaded lenses or dark glasses.

# PRODUCT DESCRIPTION

## Model 4555



**FAST. FOCUSED. CONTROLLED.**

### **Infrared Heat. Instantaneous Results.**

The Model 4555 High Density Infrared Panel heater is a modular, panel-type heating unit that combines radiant and convection heating techniques. A forced air flow system turns waste heat into usable energy and allows the heater to operate efficiently at very high power levels. This heater is available with either medium-wavelength or short wavelength lamps. You also have the choice of a ceramic reflector or an aluminum reflector.

### **Applications**

- Activating Thermo Transfer
- Ceramic Processing
- Cure and Melt Powders
- Curing
- Dry and Cure Paint
- Dry Adhesive
- Drying Coatings
- Laminating Composites
- Pre-Cure
- Preheating
- Resin Curing
- Soldering/ Desoldering
- Structural Tests
- Thermoforming
- Thick Film Drying
- Vulcanizing
- Weld Stress Relief

## Product Description-PanelIR 4555

### Heater Construction

#### Metal Housing

The Model 4555 PanelIR uses rugged stainless steel and aluminum housing to contain the lamps, blowers and reflector.

#### Reflector

A polished aluminum or ceramic reflector is installed in the housing in back of the lamps to direct the heat toward the product. The choice of ceramic or polished aluminum is based on the application.

#### Polished Aluminum Reflector

Polished Aluminum Reflectors are the most commonly used. They have a lower thermal mass than ceramic and as a result, they allow the heater to respond quicker to changes in the lamp temperature.

#### Ceramic Reflector

A ceramic reflector is generally used for applications where smoke or dirt are released as a part of the process. These contaminants will burn off of the ceramic reflector during operation so the reflector will not require cleaning. The ceramic reflector is heavier than a polished aluminum reflector and has more thermal mass so it takes as much as 10 minutes to heat up to operating temperature and to cool down when the lamps are shut off.

#### Forced Air Blowers

Blowers are installed in the housing behind the reflector. The blowers pressurize the chamber behind reflector and force air through the holes in the reflector to enhance the heating capability of the panel and to cool the end seals on the lamps.

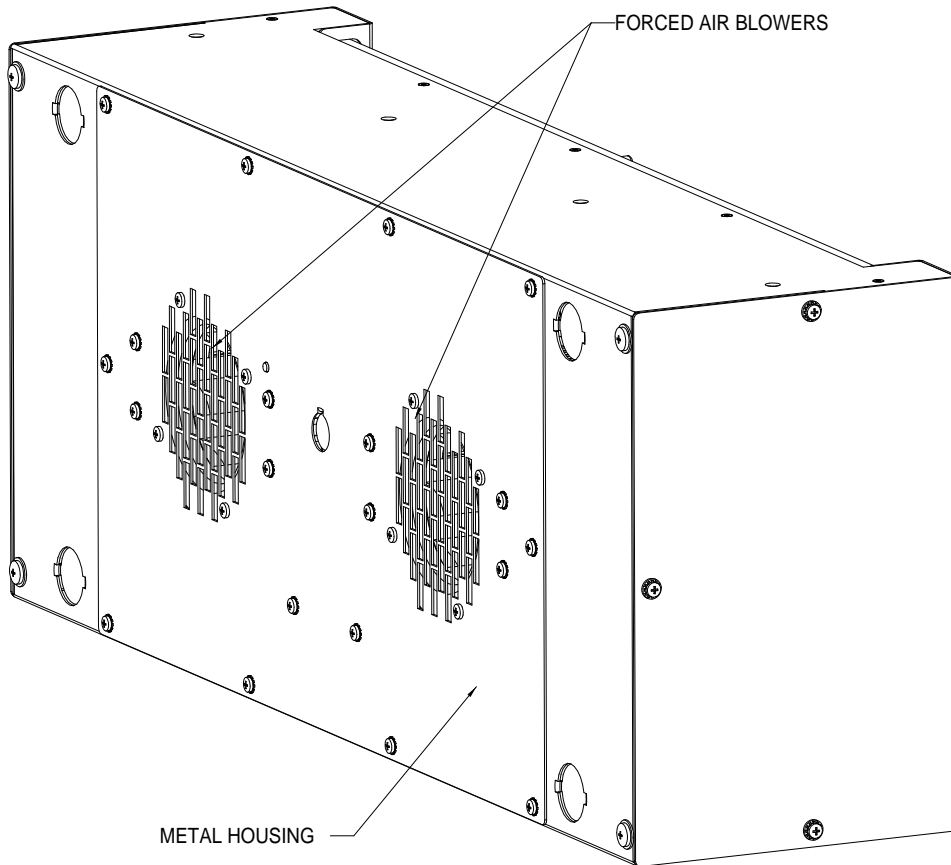

## Product Description-PanelIR 4555 cont.

### Heater Construction cont.

#### Infrared Lamps

##### Short Wavelength Lamp

These lamps are generally used in applications where a product is to be heated or cured. These lamps may be operated in horizontal or vertical orientations. Typical short wavelength applications include:

- Heat treating metals
- Annealing metals
- Localized softening plastics for bending or forming
- Curing silicone and other rubber extrusions

##### \*Limitations

Absorption of short wavelength is affected by product color. Black and dark colors absorb well. Heating lighter colors may be more readily achieved with medium wavelength lamps.

##### Medium Wavelength Lamps

These lamps are generally used in applications where a surface needs to be dried. **They may only be operated in a horizontal orientation.**

- High speed drying of water or solvent based ink
- Removing water after coil coating
- Heating substances such as Teflon that do not absorb short wavelength
- Heating lighter colored surfaces

##### \*Limitations

Medium wavelength does not penetrate as deeply into metals, plastics, or rubber as short wavelength. They may only be operated in a horizontal orientation.

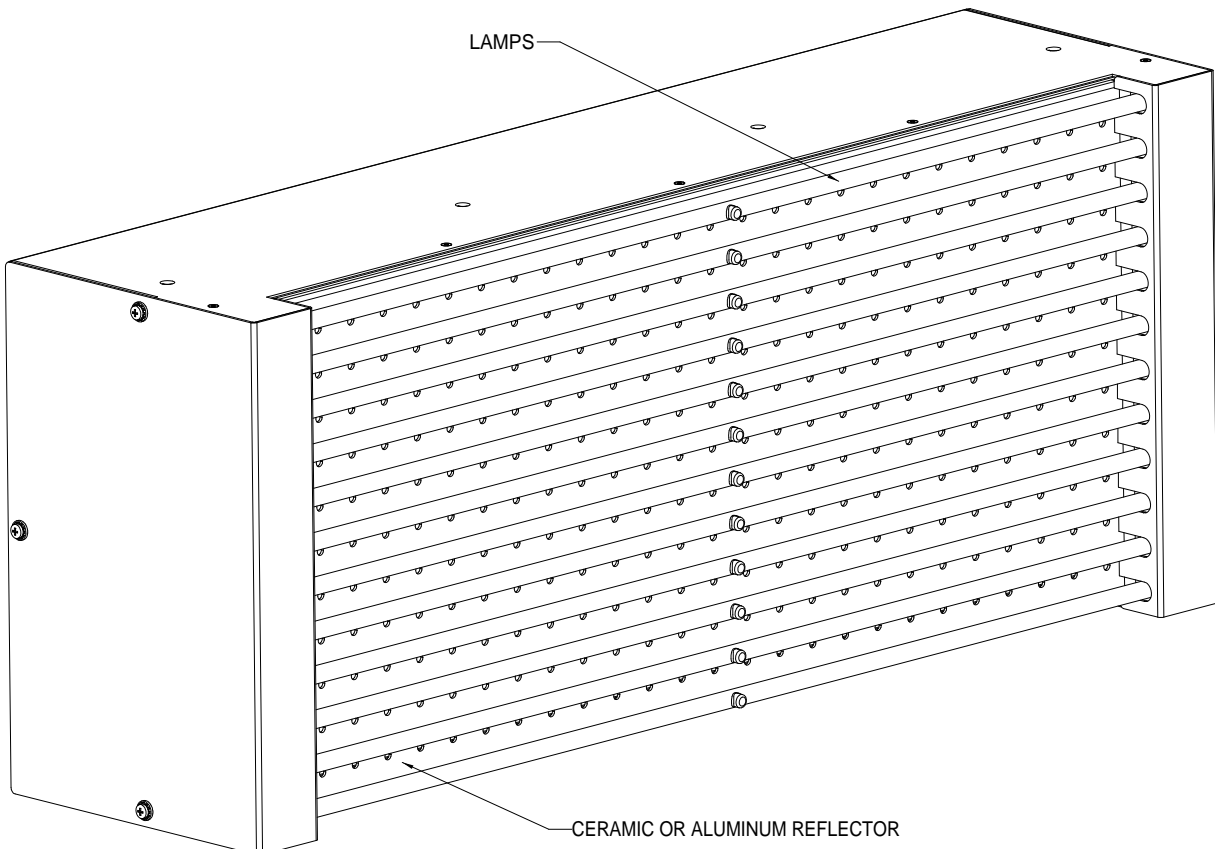

**Product Description-PanelIR 4555 cont.**

**Controls**

The model 4555 PanelIR heater is designed to be powered by one of the standard Research Inc. control panels. The model of the control panel required depends on (1) the voltage and amperage required to power the panel, (2) the electrical service in the facility, and (3) the type of temperature control required for the process.

The 900 series control panels are for single phase power and the 925 series panels are for three phase power. Both series can be specified with circuit breakers from 20 amps to 80 amps and with manual or set point control.

Terminal blocks inside the panel allow convenient termination for incoming power, all lamps and the forced air blower. A step down transformer is included in the 480 volt panel to power the 220 volt blowers.

**Power Controller Chart for Model 4555 PanelIR**

This chart shows the control panels that are available for all sizes of the Model 4555 PanelIR heater.

Heater Module	Power Controller		
	240 Volt 1 Phase	240 Volt 3 Phases	480 Volt 3 Phase
Model 4555-05-06	900-240-20		
Model 4555-05-12	900-240-40	925-240-30	
Model 4555-10-06	900-240-40	925-240-30	
Model 4555-10-09	900-240-40	925-240-30	
Model 4555-10-12	900-240-60	925-240-30	
Model 4555-16-06	900-240-60	925-240-30	925-480-30
Model 4555-16-09		925-240-60	N/A
Model 4555-16-12		925-240-60	925-480-30
Model 4555-25-06			925-480-30
Model 4555-25-09			925-480-30
Model 4555-25-12			925-480-60
Model 4555-38-06			925-480-30
Model 4555-38-09			925-480-60
Model 4555-38-12			925-480-80



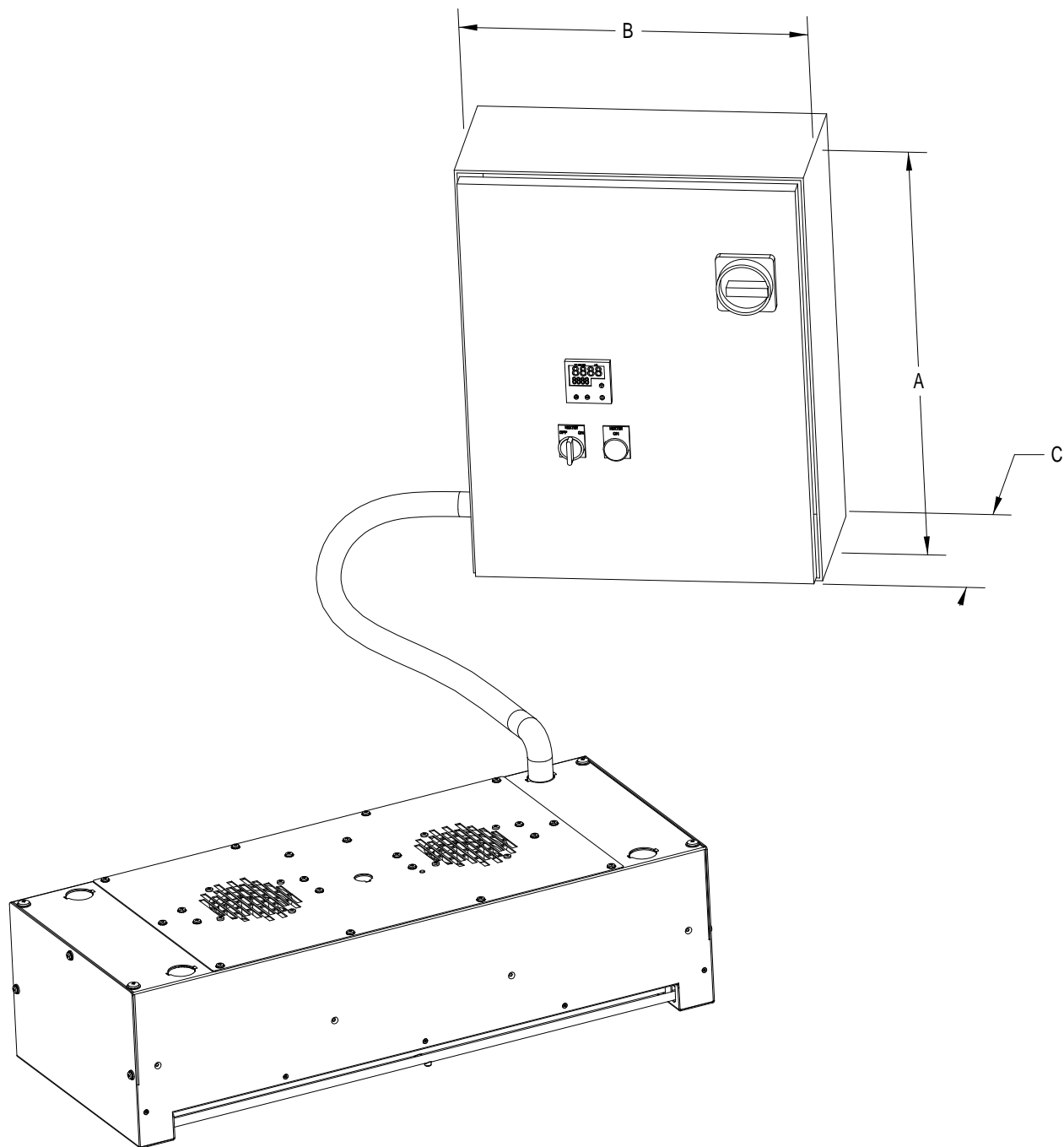

**Product Description-PanelIR 4555**

Control Panel	Voltage	Circuit Breaker	Dimensions		
Single Phase			A	B	C
Model 900-240-20	240 Volt	20 amp	20 inch	16 inch	8.62 inch
Model 900-240-40	240 Volt	40 amp	20 inch	16 inch	8.62 inch
Model 900-240-60	240 Volt	60 amp	20 inch	16 inch	8.62 inch
Three Phase					
Model 925-240-30	224 Volt	30 amp	20 inch	20 inch	8.62 inch
Model 925-240-60	240 Volt	60 amp	24 inch	24 inch	12.62 inch
Model 925-480-30	480 Volt	30 amp	20 inch	20 inch	8.62 inch
Model 925-480-60	480 Volt	60 amp	24 inch	24 inch	12.62 inch
Model 925-480-80	480 Volt	80 amp	24 inch	24 inch	12.62 inch

**Control Options**

All panels have an operator interface that allowed the heater to be controlled in any one of three operator selected modes.

**Manual Operation**

The digital control is used to directly set the percent output of the lamps from 0 to 100%.

**Automatic-Temperature Control**

The controller takes the input from a type "K" thermocouple or IR sensor and regulates the lamp output so the product temperature will match the preset value.

**Automatic-Line Speed**

The controller will take the output from a 0 to 10 VDC line that references line speed and vary the lamp output from 0 to 100% proportionally.

Once you have determined the appropriate size Model 4555 PanelIR Heater, please refer to the Power Controller to select the correct controller for your application.

**SPECIFICATIONS – PanelIR 4555**

MODEL	Lighted Length(in/mm)	Dimension A	Dimension B	Dimension C	Dimension D
Model 4555-05-06	5 (127)	8.58	5.38	6.00	9.41
Model 4555-05-12	5 (127)	8.58	10.75	12.00	9.41
Model 4555-10-06	10 (254)	13.58	5.38	6.00	14.41
Model 4555-10-09	10 (254)	13.58	7.75	9.00	14.41
Model 4555-10-12	10 (254)	13.58	10.75	12.00	14.41
Model 4555-16-06	16 (406)	19.58	5.38	6.00	20.41
Model 4555-16-09	16 (406)	19.58	7.75	9.00	20.41
Model 4555-16-12	16 (406)	19.58	10.75	12.00	20.41
Model 4555-25-06	25 (636)	28.58	5.38	6.00	29.41
Model 4555-25-09	25 (636)	28.58	7.75	9.00	29.41
Model 4555-25-12	25 (636)	28.58	10.75	12.00	29.41
Model 4555-38-06	38 (965)	41.58	5.38	6.00	42.41
Model 4555-38-09	38 (965)	41.58	7.75	9.00	42.41
Model 4555-38-12	38 (965)	41.58	10.75	12.00	42.41

**Dimensions – PanelIR 4555**

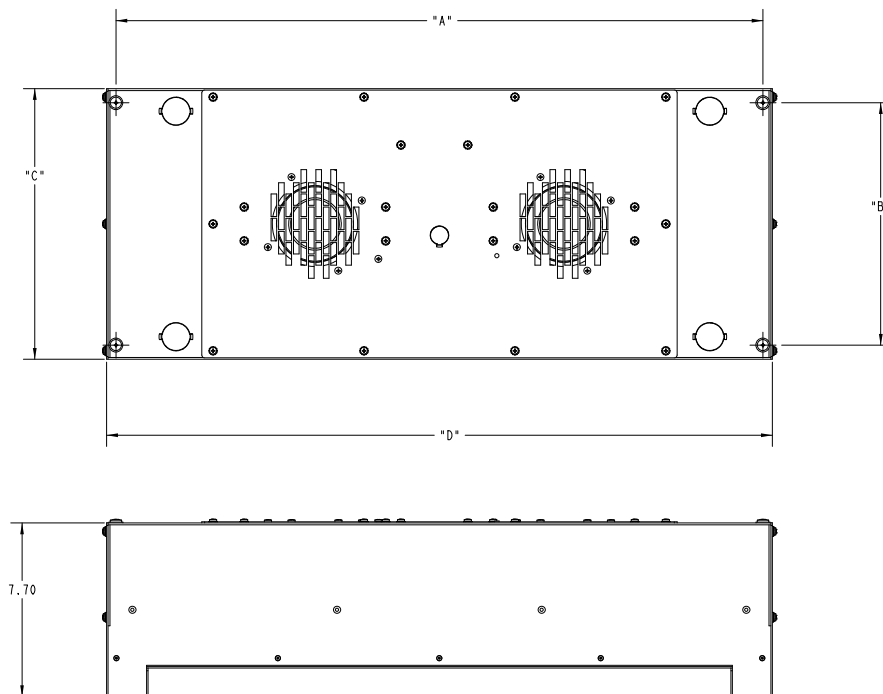

**How to Order – PanelIR Model 4555**

**1. First Specify the heater**

PRODUCT DESCRIPTIONS PanelIR Model 4555	
Model	Description
4555	PanelIR High Density Area Infrared Heater w / fan (s) Pressure Switch and Thermostat
<b>Code</b>	<b>Length</b>
5 10 16 25 38	5 inches (127mm) 10 inches (254 mm) 16 Inches (406 mm) 25 Inches (635 mm) 38 Inches (965 mm) Short wave lamps only
<b>Code</b>	<b>Lamp Width</b>
06 09 12	6 Inches (152 mm) 9 Inches (229 mm) 12 Inches (254 mm)
<b>Code</b>	<b>Lamp Type</b>
MW SW	Medium-Wave Watt-Short-Wave
<b>Code</b>	<b>Reflector Type</b>
AR CR	Aluminum Reflector Ceramic Reflector
<b>Code</b>	<b>Custom Options</b>
00	None

**\* Example: 4555-05-06-SW-AR-00**

**2. Second – Specify the Power Controller**

Heater Module	Power Controller		
	240 Volt 1 Phase	240 Volt 3 Phase	480 Volt 3 Phase
Model 4555-05-06	900-240-20		
Model 4555-05-12	900-240-40	925-240-30	
Model 4555-10-06	900-240-40	925-240-30	
Model 4555-10-09	900-240-40	925-240-30	
Model 4555-10-12	900-240-60	925-240-30	
Model 4555-16-06	900-240-60	925-240-30	925-480-30
Model 4555-16-09		925-240-60	N/A
Model 4555-16-12		925-240-60	925-480-30
Model 4555-25-06			925-480-30
Model 4555-25-09			925-480-30
Model 4555-25-12			925-480-60
Model 4555-38-06			925-480-30
Model 4555-38-09			925-480-60
Model 4555-38-12			925-480-80

**Accessories & Replacement Parts – PanelIR 4555**

ACCESSORIES AND REPLACEMENT PARTS PanelIR 4555	
Model	Description
	Set of two edge reflectors for:
ER-4555/4-05	5 inch (127 mm) length
ER-4555/4-10	10 inches (254 mm) length
ER-4555/4-16	16 inches (406 mm) length
ER-4555/4-25	25 inches (635 mm) length
ER-4555/4-38	38 inches (965 mm) length
	<b>Short Wavelength Lamps</b>
103390-001	5 inch, 500 watt
103390-003	10 inch, 1600 watt
103390-005	16 inch, 1000 watt
103390-007	25 inch, 2500 watt
103390-010	38 inch, 3800 watt
	<b>Medium Wavelength Lamps</b>
106656-001	10 inch, 1000 watt
106656-003	16 inch, 1875 watt
106656-004	25 inch, 2500 watt
M4555	Additional Operation Manual

**Mounting**

The back of the Model 4555 has four 1/4-20 X 1/2 inch screws installed for mounting purposes.

**Optional Edge Reflectors**

Edge reflectors are available to restrict the radiant energy to a rectangular area. The edge reflectors are constructed from the same materials used in the heater modules. Edge reflectors are specified in the model number or as accessories (in pairs), ordered separately from the Model 4555 heater. For arrays of multiple hookups, only one set of edge reflectors is required for the array.

# Installation

## Tools Required:

- Phillips Screwdriver
- Slotted Screwdriver
- Hammer
- Metal Punch
- Pliers
- Tape Measure
- Tin snips/Metal cutting scissors.

## MECHANICAL INSTALLATION

As shown in Figure 3-1, four ¼-20 screws are provided on the top of the Model 4555 heater for mounting purposes. The heater can be attached directly to a suitable frame structure or mounting brackets using these four screws. The distance between the heater and target should be determined before mounting the heater. The heater should be mounted so that each end cover may easily be removed for lamp installation.

Multiple Model 4555 heaters can be mounted side-by-side to form large heating arrays.

Figure 3-1 Typical installation drawing for model 4555 heater.

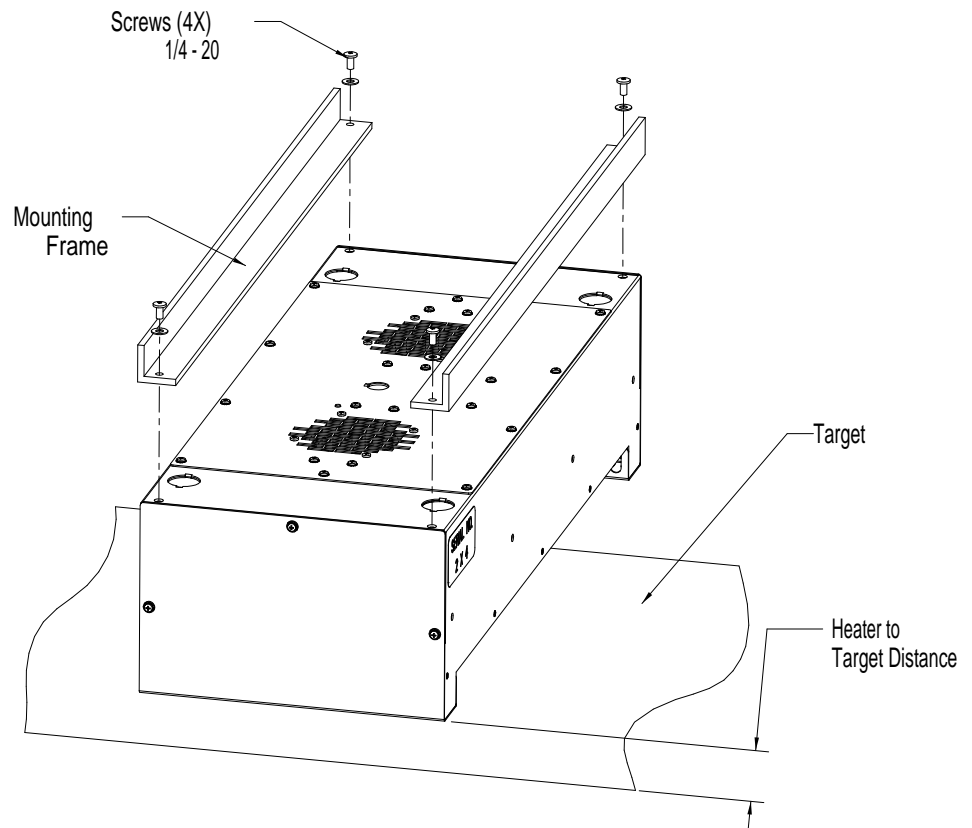

**CAUTION!**  
The back and end covers of Model 4555 heaters should not be exposed to temperatures exceeding 425°F (218°C). The heater should not be surrounded or enclosed by any type of insulating material.

**ELECTRICAL  
INSTALLATION**

**CAUTION!**  
 All internal wiring of the model 4555 Panel IR should be high temperature insulated wire as specified below or of an equivalent type:

- Lead wire type PFAH or TFE, 600V Maximum, 250°C maximum, UL listed.
- Ampacity based on National Electrical Code Table 310.

As shown in Figure 3-2, the Model 4555 contains two electrical terminal blocks, one each mounted on the internal heater housing, under each heater end cover. These terminal blocks each contain contact points for electrical connection of each lamp of the heater. In addition, each terminal strip contains a “bus bar” that provides electrical connection between all contact points on the terminal block (Figure 3-2).

Figure 3-2 Terminal Strip and Bus Bar

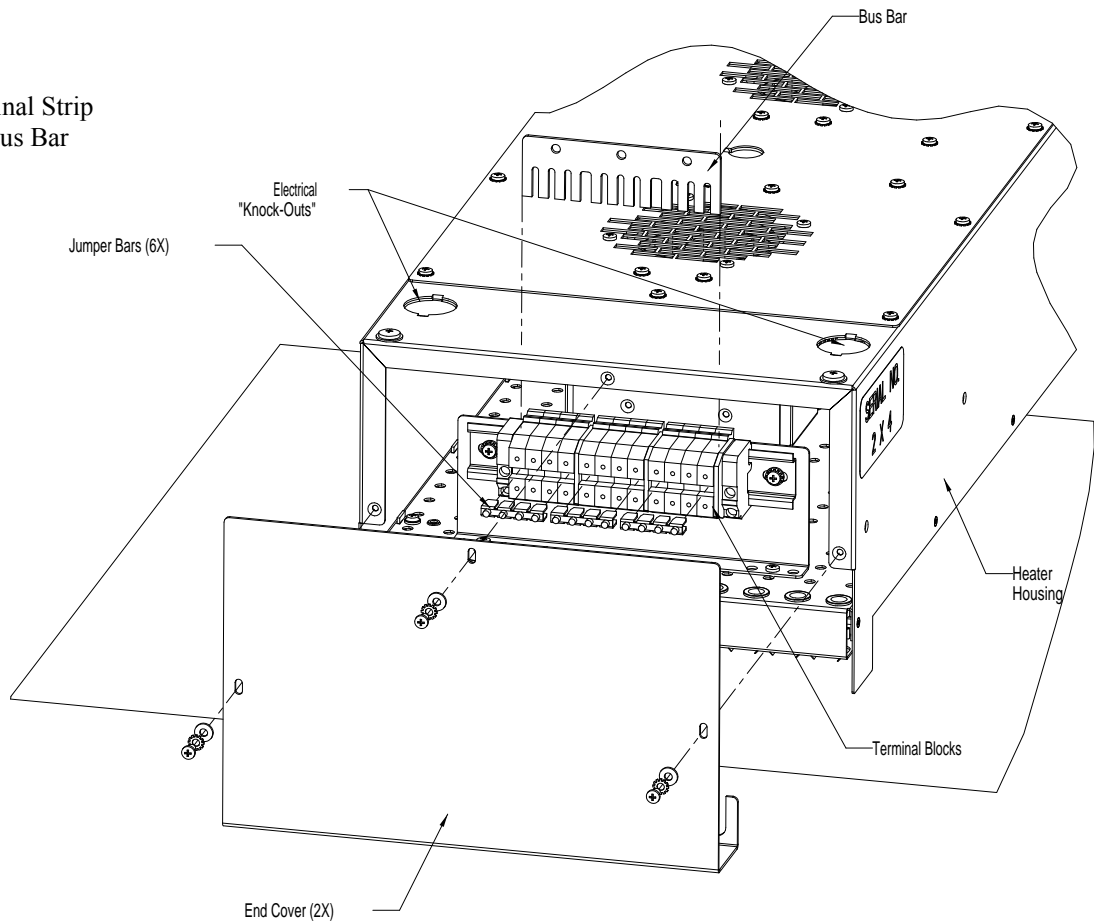

The presence of the bus and jumper bars on each terminal block allows the heater to be easily wired in different configurations. A model 4555 heater wired in a single-zone configuration is shown in Figure 3-3. In this configuration the lamps mounted in the Model 4555 all simultaneously receive the same voltage from the power source. In this case, electrical connection from each terminal block to the power source is made by a single, high temperature grade, electrical wire as follows:

Figure 3-3 Single Zone Wiring

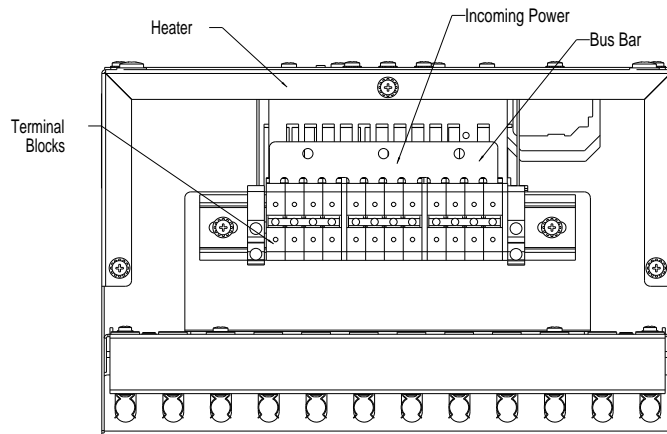

**WARNING!**  
 The electrical power required to operate the 4555 is extremely dangerous. Make sure all electrical power that is to be provided to the Model 4555 is adequately turned off prior to making any electrical connection to the heater.

**NOTE:**  
 The following instructions are for single-phase electrical wiring of the Model 4555. See next section for three-phase wiring.

Figure 3-4 Single Zone Single Phase Schematic

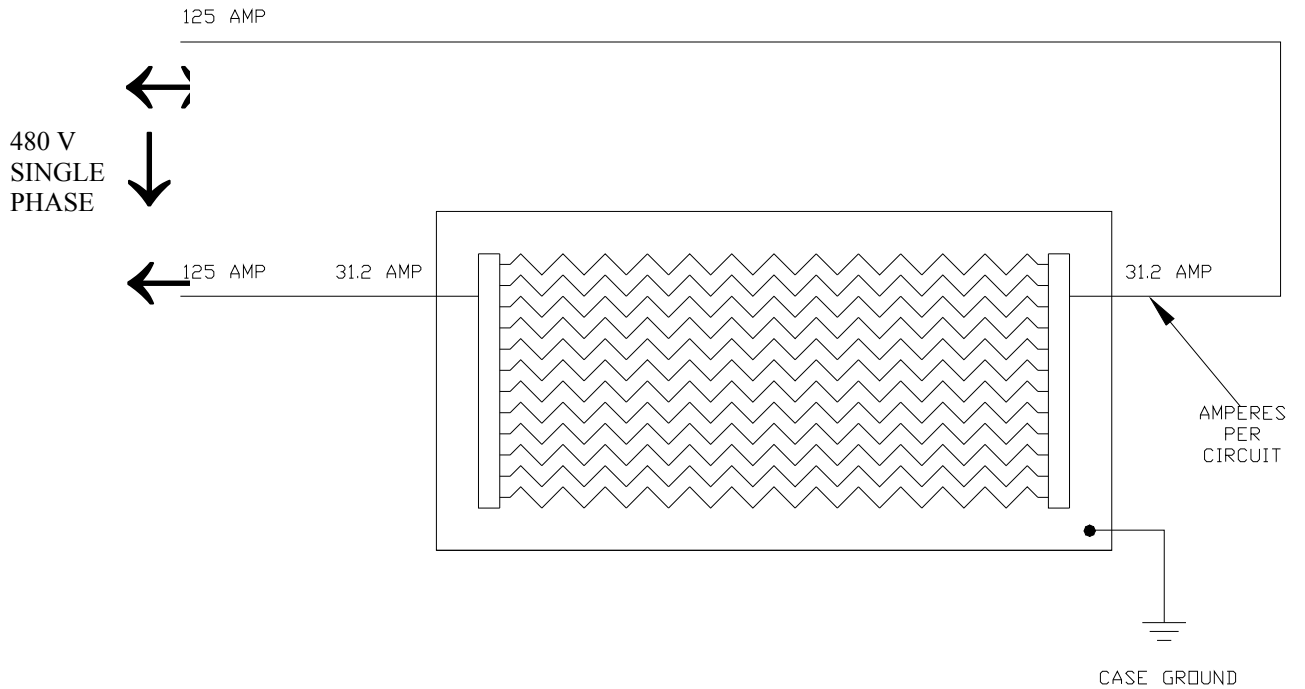



## Single Phase Wiring

- |   |  |
|---|--|
| Prepare heater unit for wiring            | <ol style="list-style-type: none"><li>1. Remove the three screws from each of the end covers on each end of the heater using the Phillips screwdriver.</li><li>2. Carefully remove each of the end covers and set them aside so that they are not damaged.</li></ol>   |
| Remove electrical connection “knock-outs” | <ol style="list-style-type: none"><li>1. Using the hammer and punch, remove one circular “knock-out” from each end of the top of the heater by placing the metal punch on the knock-out outline and striking the punch with the hammer until the knock-out protrudes into the heater.</li><li>2. Using the pliers, remove both knock-out slugs from the heater body.</li><li>3. Discard the knock-out slugs.</li></ol>   |
| Install high temperature wire             | <ol style="list-style-type: none"><li>1. On each end, use the tape measure to measure the distance from the center of each terminal block to the point at which the supply power and the high temperature wire are to be joined.</li><li>2. Include additional length to account for wire travel through the knock-out hole and enough to perform adequate wire stripping prior to attachment to the heater and power supply wiring.</li><li>3. Cut two lengths of high temperature wire corresponding to the measured lengths.</li><li>4. Strip the insulation from each end of each wire to expose the conductor material (approximately ½”)</li><li>5. Feed one wire (each) into the heater through each end of the heater between the terminal blocks and the back of the heater and up through the knock-out hole. Install the wires into the terminal blocks (see Figure 3-4).</li><li>6. If the amp draw is 50 amps or less, the stripped end of the wire can be inserted directly into the terminal block. If it is greater than 50 amps, attach a ring lug to the end of the wire and install the ring onto the bus bar with a screw and nut.</li></ol> |
| Wiring Power to Heater                    | <ol style="list-style-type: none"><li>1. Attach the unconnected end of each high temperature wire to the power supply wiring using appropriate wire joining techniques (as specified by local electrical codes and standards).</li></ol>   |

## Three Phase Wiring

### Prepare heater unit for wiring

1. Remove the three screws from each of the end covers on each end of the heater using the Phillips screwdriver.
2. Carefully remove each of the end covers and set them aside so that they are not damaged.
3. Remove the Bus Bars from the terminal blocks. Leave the jumper bars in place.

### Remove electrical connection “knock-outs”

1. Using the hammer and punch, remove one circular “knock-out” from each end of the top of the heater by placing the metal punch on the knock-out outline and striking the punch with the hammer until the knock-out protrudes into the heater.
2. Using the pliers, remove both knock-out slugs from the heater body.
3. Discard the knock-out slugs.

### Install high temperature wire

1. On each end, use the tape measure to measure the distance from the center of each terminal block to the point at which the supply power and the high temperature wire are to be joined.
2. Include additional length to account for wire travel through the knock-out hole and enough to perform adequate wire stripping prior to attachment to the heater and power supply wiring.
3. Cut three lengths of high temperature wire corresponding to the measured lengths.
4. Strip the insulation from each end of each wire to expose the conductor material (approximately ½”)
5. Feed one wire into the heater through one knock-out and two wires through the other. Install the wires into the terminal blocks.
6. Jumper wires will need to be installed into the terminal blocks to complete the three phase circuit (see Figure 3-5)

1. Attach the unconnected end of each high temperature wire to the power supply wiring using appropriate wire joining techniques (as specified by local electrical codes and standards).

### Wiring Power to Heater

Figure 3-5 Single Zone 3  
Phase Wiring  
Diagram

TYPICAL 3 PHASE CONNECTION

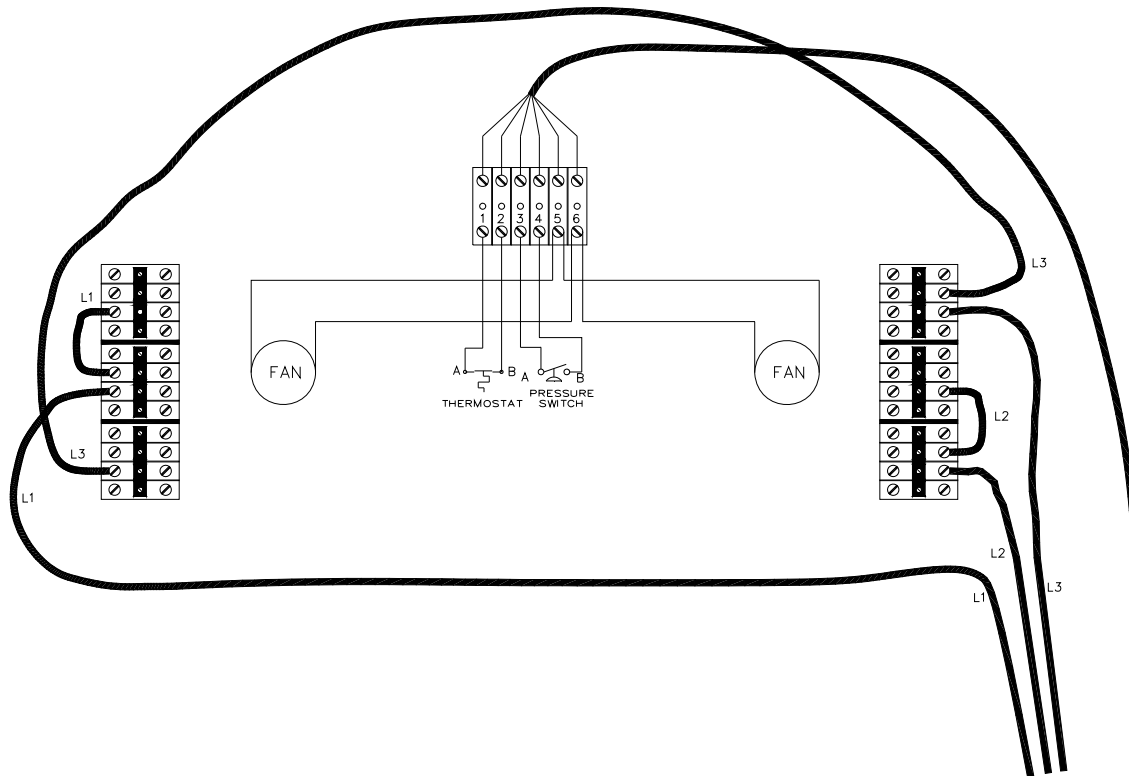

## Multi-Zone Wiring

The Model 4555 can also be wired so that multiple heating zones are produced within the heater. When configured for multi-zone operation, each zone of lamps is electrically controlled by its own power control device. Wiring the Model 4555 for multi-zone operation is as follows:

## Prepare heater unit for wiring

1. Remove the three screws from each of the end covers on each end of the heater using the Phillips screwdriver.
2. Carefully remove each of the end covers and set them aside so that they are not damaged.

Remove electrical connection  
“knock-outs”

1. Three knock-outs are provided on each end of the Model 4555. Multiple knock-outs can be removed on each end of the heater so that an individual knock-out does not have to accommodate more than three or four wires. It is left up to the installer to determine the number of knock-outs to remove to simplify the wiring procedure.
2. Using the hammer and punch, remove one circular “knock-out” from each end of the top of the heater by placing the metal punch on the knock-out outline and striking the punch with the hammer until the knock-out protrudes into the heater.
3. Using the pliers, remove the knock-out slugs from the heater body.
4. Discard the knock-out slugs.

1. Using the slotted screwdriver, loosen the screws holding the bus bar in the terminal blocks.
2. Lift the bus bar out of the terminal strip.
3. As shown in Figure 3-6, the bus and jumper bars can be cut to produce shorter, individual jumpers corresponding to the number of desired heating zones. For zones with more than 4 lamps, cut the bus bar the desired length. Use the jumper bars for zones with 4 lamps or less. Move the plastic spacers so that they are between the terminal blocks for each zone. They are required to insure electrical isolation between zones.
4. Tighten each of the screws in the terminal blocks and jumper bars.

Figure 3-6 Multi-Zone Bus Bar Preparation

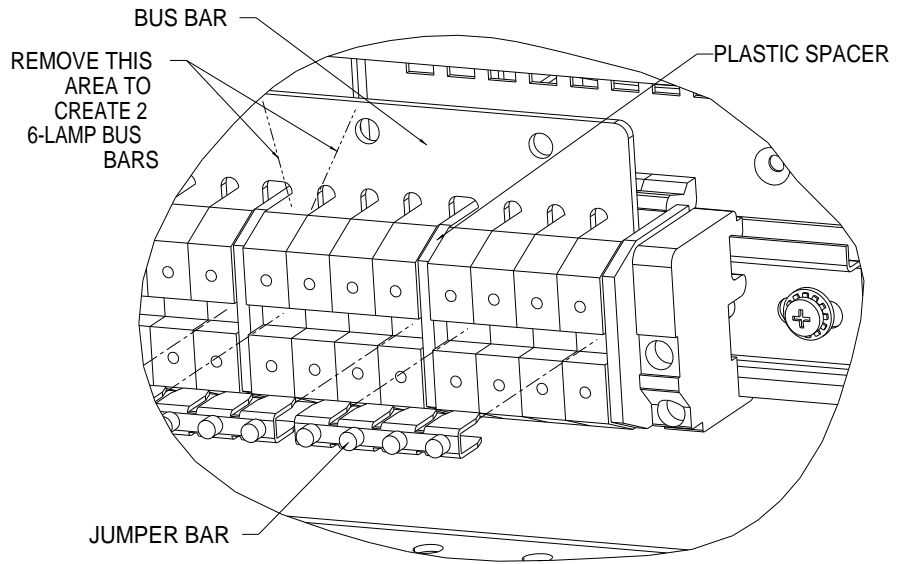

Install high temperature wire

1. On each end, use the tape measure to measure the distance from the center of each terminal strip 'zone' to the point at which the supply power and the high temperature wire are to be joined.
2. Include additional length to account for wire travel through the knock-out hole and enough to perform adequate wire stripping prior to attachment to the heater and power supply wiring.
3. Cut lengths of high temperature wire corresponding to the measured lengths.
4. Strip the insulation from each end of each wire to expose the conductor material (approximately 1/2").
5. Feed the wires into the heater through each end of the heater between the terminal strip and the back of the heater and up through the knock-out holes.
6. If the amp draw is 50 amps or less, the stripped end of the wire can be inserted directly into the terminal block. If it is greater than 50 amps, attach a ring lug to the end of the wire and install the ring onto the bus bar with a screw and nut.

Wiring Power to Heater

Attach the unconnected end of each high temperature wire to the power supply wiring using appropriate wire joining techniques (as specified by local electrical codes and standards).

## Lamp Installation

### CAUTION!

Wear soft, clean, oil free flannel or plastic gloves when handling halogen, quartz lamps. Oils and contaminants are readily transmitted to the quartz by unprotected hands and can cause premature lamp failure.

### Lamp Mounting

1. Insert the lamp lead wires through the reflector and snap the lamp into the spring clips provided (Figure 3-7). If the lamp clips are excessively tight, gently spread the clip wider. Make sure that the lamp is held securely in the clip.

### CAUTION!

It is important that the lead wire between the lamp and terminal block not be pulled tight when the lamp is installed. As the heater module and lamps heat and cool, they are also expanding and contracting which may damage the lamp if the lead is too tight.

2. Insert the lamp lead wire into terminal blocks and tighten the screw terminal. Make sure that the terminal block is not tightened on the insulation of the wire.
3. When all of the lamps have been installed, check for electrical shorts to the heater's metal chassis

Figure 3-7 Lamp installation

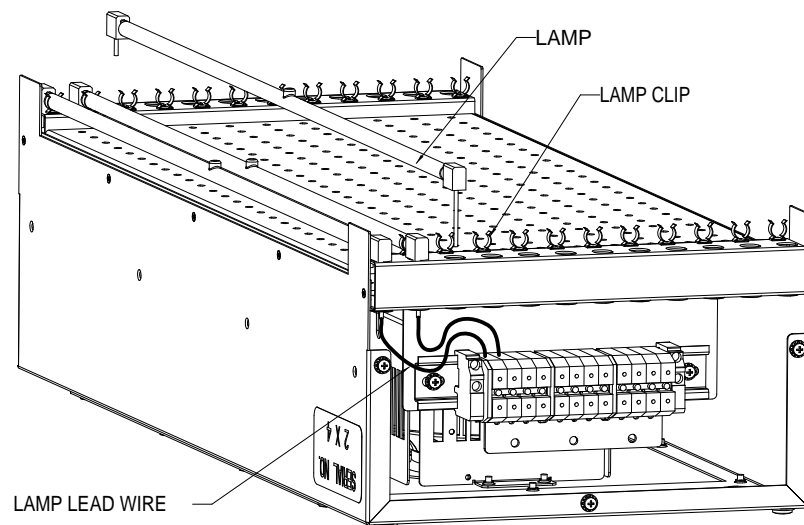

4. Carefully replace each end cover in its proper location on the heater body.
5. Insert the three screws that hold the end cover in place into their respective holes and tighten them into the heater using the Phillips screw driver

### Wiring Thermostat

A thermostat is mounted to the backside of the Model 4555 air plenum inside the heater body (Figure 3-8). The thermostat is a feature of the model 4555 that safeguards the heater from overheating. The thermostat is rated for 120 volt 15 amp service. When properly wired to the heater power control system, the thermostat will trip if it reaches a temperature of 180° F (82° C) resulting in loss of power to the heater if wired to operate in this configuration. The thermostat will reset after it cools below a temperature of 150° F (66° C). The thermostat is wired to terminal blocks 1-2 (Figures 3-9,10).

Figure 3-8 Thermostat wiring

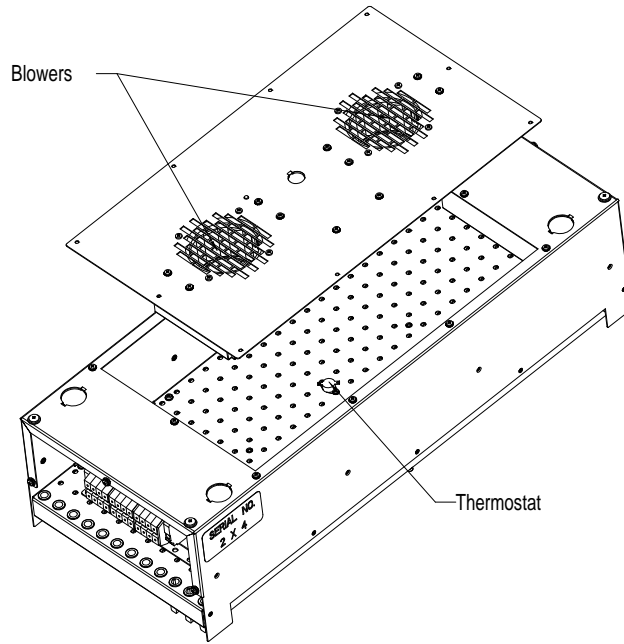

### Pressure Switch Wiring

A pressure switch is mounted to the fan bracket inside the heater body (Figure 3-7). The pressure switch is a feature of the Model 4555 that safe guards the heater from loss of cooling air. The pressure switch is rated for 24 VDC, 20-ma service. When properly wired to the heater power control system, the pressure switch will trip if the heater body losses pressure due to blower stoppage or intake clogging, resulting in loss of power to the heater. The pressure switch will reset when blower function resumes. The Pressure switch is wired to terminal blocks 3-4 (Figures 3-9,10).

Figure 3-9 Pressure Switch  
Thermostat, and  
Blower Wiring

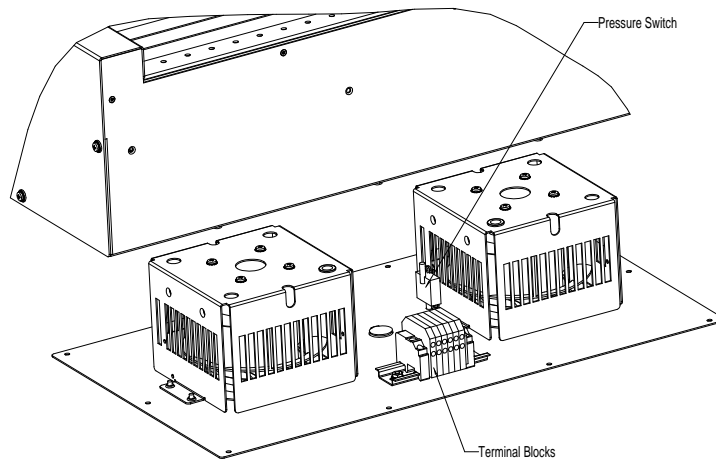

### Forced Air Blower Wiring

The Model 4555 has an integral blower to provide cooling air to the lamps and reflectors. The blowers operate on 230 VAC 50/60 Hz. The blowers are wired to terminal blocks 5-6 (Figures 3-9,10). All applicable electrical standards and codes must be followed when wiring the forced air blowers.

Figure 3-10 Blower, Thermostat and Pressure Switch Wiring Diagram

FAN, THERMOSTAT AND PRESSURE SWITCH WIRING

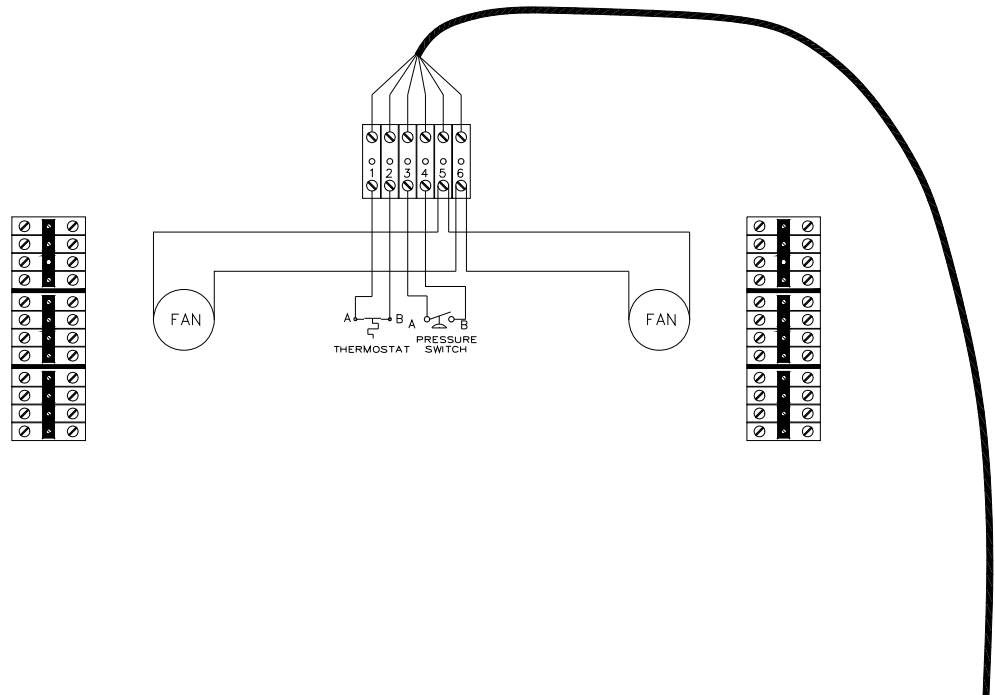



# Operating Instructions

Operation of the Model 4555 is relatively straightforward once installed and properly (electrically) wired to an appropriate power control source. In addition, the forced-air blower system, pressure switch and heater thermostat must be connected to an appropriate power supply in order to operate.

The intensity of the infrared energy generated by the lamps is directly proportional to the amount of electrical power supplied to the lamps. Determining the amount of electrical power supplied to the lamps in the Model 4555 depends on a variety of parameters including (but not limited to):

- Infrared absorptivity of target product (e.g. Target material properties including: color, surface condition, and temperature).
- Desired product heating rate.
- Minimum/maximum target product temperature.
- Distance from heater to target product.
- Speed of target product moving through the heating area.

In general, a limited number of experimental tests to determine the optimal settings (i.e. heater-to-target distance, applied power to the lamps, product target speed through the heating area, etc.) should be performed for any Model 4555 installation. Following this approach will yield the best operational settings for a given application.

Depending on the application (and if feasible), a temperature control feed back system may be used to control the energy output of the Model 4555. A typical control system includes power control, temperature measurement capability, target product tachometer feed back (moving target applications), and alarm/emergency shut down capability. Employing such a system allows for continuous monitoring of the heating process and ensures continuous, steady state infrared energy output from the heater.

Beyond routine, periodic maintenance (See Section 5—Maintenance) and following all safety practices (See Section 1—Safety) the Model 4555 requires no additional care or handling for correct, efficient operation.

# Maintenance

Periodic inspection for dirt and contaminants on the heater, blower mechanism, and lamps, and removal of such, will ensure that the Model 4555 continues to operate efficiently and will extend lamp life.

In dirty environments or heating operations the lamps may become contaminated by, dust, fingerprints or other foreign matter. When this occurs it is recommended that they be cleaned using the following procedure:

**WARNING!**

Disconnect all power running to the Model 4555 from the power source and allow the heater to cool at least five minutes before continuing.

**CAUTION!**

Wear soft, clean oil-free flannel or plastic gloves when handling quartz lamps. Skin oils and other contaminants can cause premature lamp failure if they are allowed to reside on the quartz lamp.

Using a soft, dry, cloth or tissue, wipe the residue from contaminated lamps. A solution of household strength ammonia and water can be used as a solvent.

The reflector for the Model 4555 heater is made from either polished aluminum or a high temperature ceramic material. The ceramic reflector is essentially self-cleaning. Surface heat normally prevents contaminant condensation on the reflector. Increasing power to the lamp for short time periods will increase the heater temperature resulting in the removal of most contaminants.

The aluminum reflector can be maintained by cleaning with a soft cloth or tissue. If the reflector gets scratched or dull, it can be polished with aluminum polish.

# Appendix A Multiple Heater Wiring

## DETERMINING THE CURRENT PER LAMP

1. Calculate the percentage of the applied voltage to the lamp's rated voltage:

$$\text{Percent Voltage} = \frac{\text{Applied Voltage X 100}}{\text{Rated Voltage of Lamp}}$$

2. Use Figure A-1 to determine the percent of power dissipated by the lamps at that percent voltage. Or for greater accuracy, calculate the percent of power dissipated:

$$\text{Percent of Power Dissipated} = (\text{Percent Voltage})^{1.54}$$

3. Determine the power dissipated:

$$\text{Dissipated Power} = \text{Percent of Power Dissipated X Rated Power}$$

4. Calculate the lamp current:

$$\text{Lamp Current} = \frac{\text{Dissipated Power}}{\text{Applied Voltage}}$$

Example: Assume a 3800 T3, 3800 watt, 570 volt lamp is to operate in a 440 volt line.

1.  $\text{Percent Voltage} = \frac{440 \text{ Applied Voltage X 100}}{570 \text{ Rated Voltage of Lamp}} = 77\%$
2. The percent-dissipated power at 77% of rated load is about 67%. Or to calculate:  $\text{Percent of Power Dissipated} = (.77)^{1.54} = 66.8\%$  or 67%
3.  $\text{Dissipated Power} = 67\% \text{ Percent of Power Dissipated X } 3800 \text{ Watts} = 2546 \text{ watts}$
4.  $\text{Lamp Current} = \frac{2546 \text{ Watts Dissipated Power}}{440 \text{ volts Applied Voltage}} = 5.78 \text{ Amperes}$

Figure A-1 Voltage and Temperature

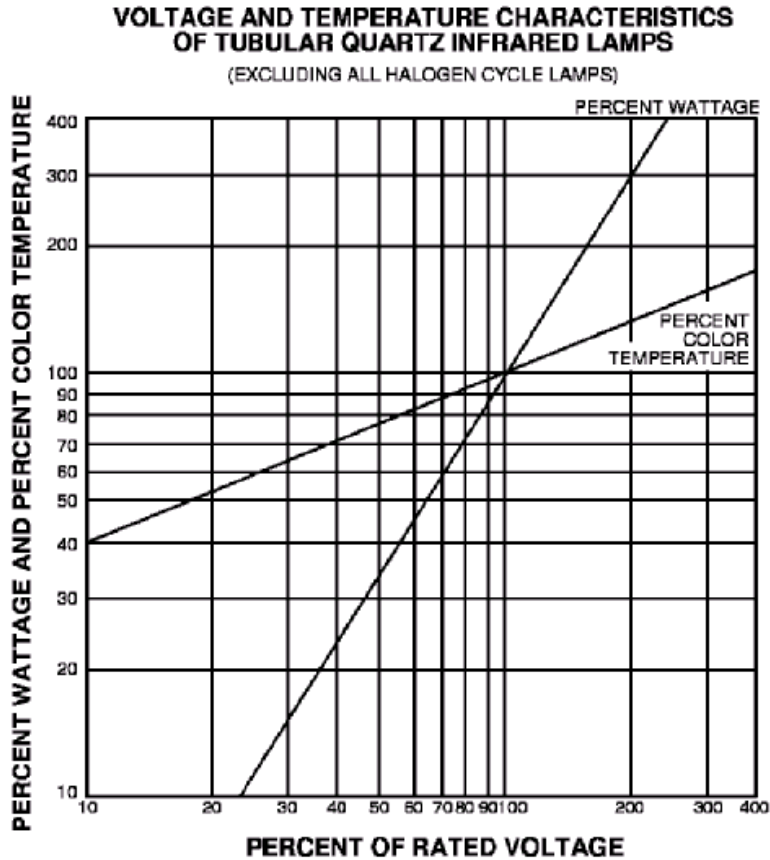

**POWER DISSIPATION VS. VOLTAGE FORMULA**

$$\frac{W_A}{W_R} = \left(\frac{V_A}{V_R}\right)^{1.54}$$

$$W_A = W_R \left(\frac{V_A}{V_R}\right)^{1.54}$$

$W_A$  = Actual Power Dissipated, Watts  
 $W_R$  = Rated Power, Watts  
 $V_A$  = Lamp Voltage, Actual  
 $V_R$  = Lamp Voltage, Rated

Single Phase Loads

The line current for single-phase loads can be calculated using one of the following methods:

1. Determine the current per lamp. If the applied voltage to the lamps is different, calculated the lamp current as explained on page 21.
2. Determine the number of lamps.
3. Calculate the line current:

$$\text{Line Current} = \text{Lamp Current} \times \text{Number of Lamps.}$$

Example: Assume quantity 2 Model 4555-25-12 using 2500 T3 lamps connected to a 480 volt source (see Figure A-2).

1. The current per 2500T3 lamp connected to a 480 volt source is 5.2 amperes.
2. The number of lamps in each Model 4555-25-12 is 12. Quantity 2 Pyropanels X 12 Lamps = 24 lamps total (see Figure A-2).
3. Line Current = 5.2 Amperes X 24 Lamps = 125 Amperes.

Figure A-2 Single-Phase or DC Input Wiring Diagram

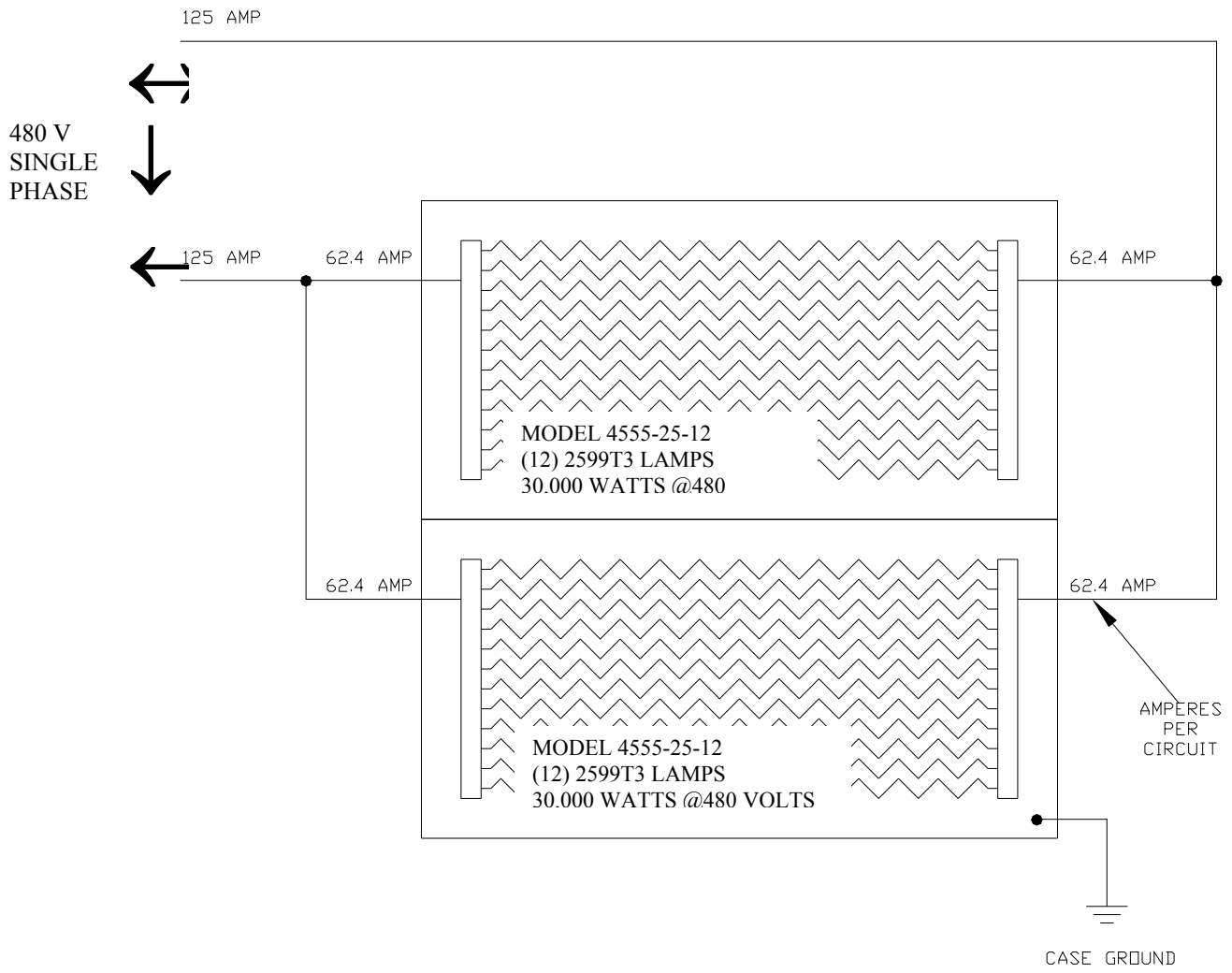

**Three Phase Balanced Loads** A three-phase load is one where the load for all three phases dissipates the same power. In the case of the Model 4555, there should be an equal number of the same wattage lamps connected to each phase.

The line current for three phase loads can be calculated using one of the following methods:

1. Determine the power dissipated per lamp.
2. Determine the number of lamps.
3. Calculate the total power dissipated in the load.
4. Calculate the line current:

$$\text{Line Current} = \frac{\text{Load Power}}{\text{Applied Voltage} \times 1.73}$$

**Example:** Assume quantity 3 Model 4555-25-12 using 2500T3 lamps connected to a 480 volt source (see Figure A-3).

1. The power dissipated by a 2500T3 lamp is 2.5 kW, or 2500 watts, when connected to a 480 volt source.
2. The number of lamps in each Model 4555-25-12 is 12. Quantity 3 Pyropanels X 12 lamps = 36 lamps total.
3. Load power = 2,500 Watts dissipated per lamp X 36 lamps = 90,000 Watts
4. Line Current =  $\frac{90,000 \text{ Watts Load Power}}{480 \text{ Volts Applied} \times 1.73} = 108 \text{ Amperes.}$

Figure A-3 Balanced Three-Phase Load Wiring Diagram

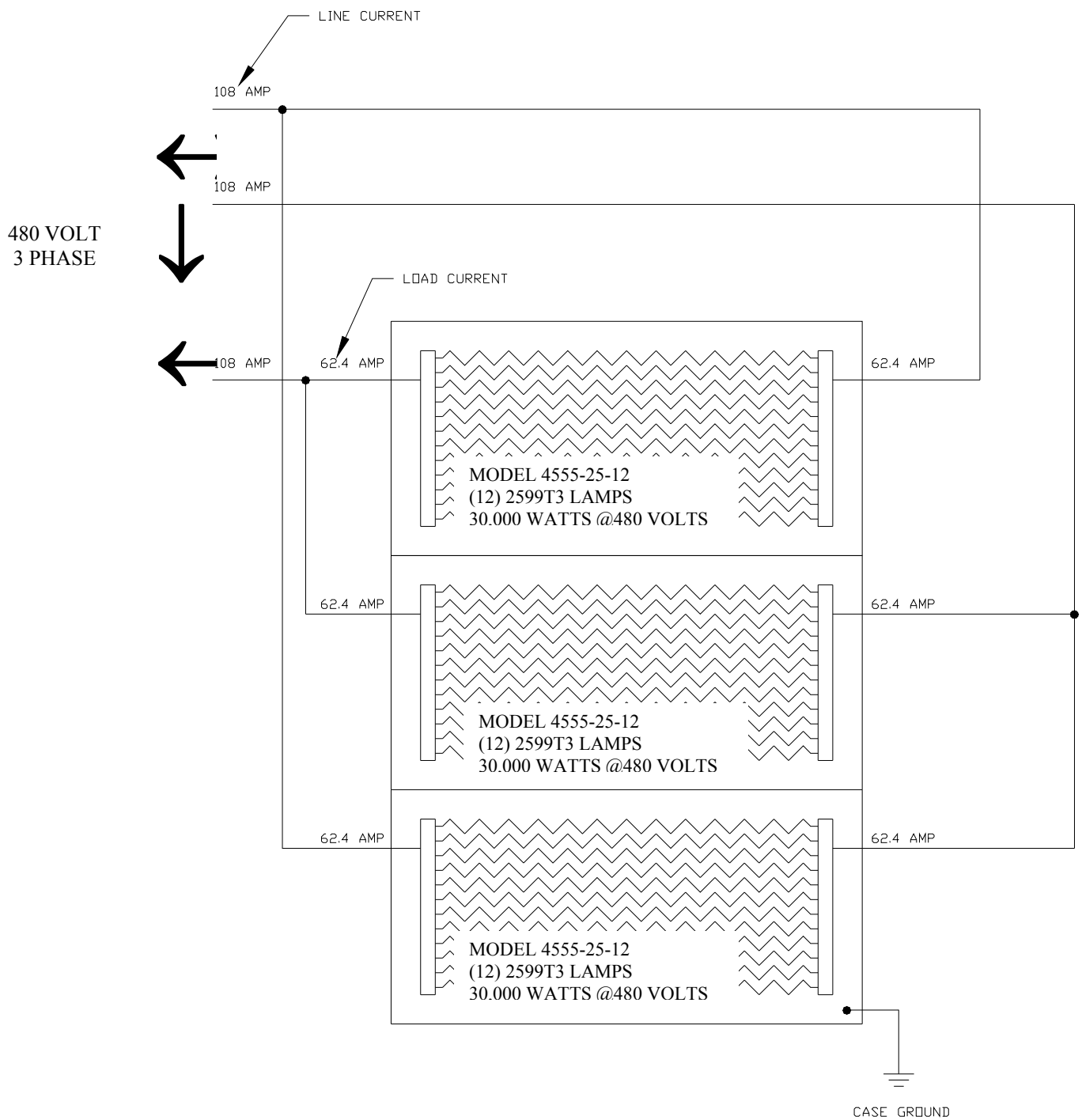

**Three-Phase Unbalanced Loads**

Often it is not possible to connect the lamps in the Model 4555 to make a balanced load. In this case, the three line currents supplying the heater lamps can be calculated as follows:

1. Determine the number of lamps in each load.
2. Determine the current per lamp.
3. Calculate the load current for each of the three loads based on the number of lamps in each load and the current per lamp.

**Line current = Lamp Current x Number of Lamps in Load.**

4. Calculate the line current based on the current of the two loads connected to the line:

$$\text{Line Current} = \sqrt{(\text{FLC}^2 + (\text{FLC} \times \text{SLC}) + \text{SLC}^2)}$$

**NOTE:**

*FLC = First Load Current*

*SLC = Second Load Current*

Example: Assume quantity 2 Model 4555-25-12 and quantity 1 Model 4555 25-06 using 2500T3 lamps connected to a 480 volt source (see Figure A-4).

1. Number of lamps in each load  
 Load 1 = 12 lamps  
 Load 2 = 12 lamps  
 Load 3 = 6 lamps
2. The current per 2500T3 lamp connected to a 480 volt source is 5.2 amperes.
3. Load Current 1 – 5.2 Amperes x 12 Lamps = 62.4 Amperes  
 Load Current 2 – 5.2 Amperes x 12 Lamps = 62.4 Amperes  
 Load Current 3 – 5.2 Amperes x 6 Lamps = 31.2 Amperes
4. Line Current 1 =  $\sqrt{(\text{LC1}^2 + (\text{LC1} \times \text{LC3}) + \text{LC3}^2)} = \sqrt{(62.4^2 + (62.4 \times 31.2) + 31.2^2)}$   
 Line Current 2 =  $\sqrt{(\text{LC2}^2 + (\text{LC2} \times \text{LC3}) + \text{LC3}^2)} = \sqrt{(62.4^2 + (62.4 \times 31.2) + 31.2^2)}$   
 Line Current 3 =  $\sqrt{(\text{LC1}^2 + (\text{LC1} \times \text{LC2}) + \text{LC2}^2)} = \sqrt{(62.4^2 + (62.4 \times 62.4) + 62.4^2)}$



Figure A-4 Unbalanced  
Three-Phase Load  
Wiring Diagram

